

## Ransburg DR-1 Fluid Regulator



Model: 74151

**IMPORTANT:** Before using this equipment, carefully read SAFETY PRECAUTIONS, starting on page 4, and all instructions in this manual. Keep this Service Manual for future reference.

**NOTE:** This manual has been changed from revision **LN-9223-00.11** to revision **LN-9233-00-R12**. Reasons for this change are noted under “Manual Change Summary” inside the back cover of this manual.

# CONTENTS

<b>SAFETY:</b>	<b>4-8</b>
Safety Precautions .....	4
Hazards / Safegaurds .....	5
<b>INTRODUCTION:</b>	<b>9-10</b>
Features .....	9
Specifications .....	9
DR-1 Flow vs. Signal Pressure .....	10
<b>OPERATION:</b>	<b>11</b>
Operation .....	11
<b>MAINTENANCE:</b>	<b>12-17</b>
Tools Required .....	12
Preliminary Procedures .....	12
Disassembly Procedures .....	12
Regulator Cross-Sectional View .....	13
Assembly Procedures .....	14
Test Procedures .....	15
Preventive Maintenance .....	15
Troubleshooting Guide .....	16
<b>PARTS IDENTIFICATION:</b>	<b>18-20</b>
Regulator Cross-Sectional View .....	18
DR-1 Fluid Regulator Parts List.....	19
Recommended Spare Parts .....	20
Service Kits .....	20
<b>MANUAL CHANGE SUMMARY:</b>	<b>21</b>
Manual Changes .....	21

# SAFETY

## SAFETY PRECAUTIONS

Before operating, maintaining or servicing any Ransburg electrostatic coating system, read and understand all of the technical and safety literature for your Ransburg products. This manual contains information that is important for you to know and understand. This information relates to **USER SAFETY** and **PREVENTING EQUIPMENT PROBLEMS**. To help you recognize this information, we use the following symbols. Please pay particular attention to these sections.

### WARNING

A **WARNING!** states information to alert you to a situation that might cause serious injury if instructions are not followed.

### CAUTION

A **CAUTION!** states information that tells how to prevent damage to equipment or how to avoid a situation that might cause minor injury.

### NOTE

A **NOTE** is information relevant to the procedure in progress.

While this manual lists standard specifications and service procedures, some minor deviations may be found between this literature and your equipment. Differences in local codes and plant requirements, material delivery requirements, etc., make such variations inevitable. Compare this manual with your system installation drawings and appropriate Ransburg equipment manuals to reconcile such differences.

Careful study and continued use of this manual will provide a better understanding of the equipment and process, resulting in more efficient operation, longer trouble-free service and faster, easier troubleshooting. If you do not have the manuals and safety literature for your Ransburg system, contact your local Ransburg representative or Ransburg.



### WARNING

- The user **MUST** read and be familiar with the Safety Section in this manual and the Ransburg safety literature therein identified.
- This equipment is intended to be used by trained personnel **ONLY**.
- This manual **MUST** be read and thoroughly understood by **ALL** personnel who operate, clean or maintain this equipment! Special care should be taken to ensure that the **WARNINGS** and safety requirements for operating and servicing the equipment are followed. The user should be aware of and adhere to **ALL** local building and fire codes and ordinances as well as **NFPA-33 AND EN 50176 SAFETY STANDARDS, LATEST EDITION**, or applicable country safety standards, prior to installing, operating, and/or servicing this equipment.



### WARNING

- The hazards shown on the following pages may occur during the normal use of this equipment. Please read the hazard chart beginning on page 2.

<p><b>AREA</b> Tells where hazards may occur.</p>	<p><b>HAZARD</b> Tells what the hazard is.</p>	<p><b>SAFEGUARDS</b> Tells how to avoid the hazard.</p>
<p><b>Spray Area</b></p> 	<p><b>Fire Hazard</b></p> <p>Improper or inadequate operation and maintenance procedures will cause a fire hazard.</p> <p>Protection against inadvertent arcing that is capable of causing fire or explosion is lost if any safety interlocks are disabled during operation. Frequent Power Supply or Controller shutdown indicates a problem in the system requiring correction.</p>	<p>Fire extinguishing equipment must be present in the spray area and tested periodically.</p> <p>Spray areas must be kept clean to prevent the accumulation of combustible residues.</p> <p>Smoking must never be allowed in the spray area.</p> <p>The high voltage supplied to the atomizer must be turned off prior to cleaning, flushing or maintenance.</p> <p>Spray booth ventilation must be kept at the rates required by NFPA-33, OSHA, country, and local codes. In addition, ventilation must be maintained during cleaning operations using flammable or combustible solvents.</p> <p>Electrostatic arcing must be prevented. Safe sparking distance must be maintained between the parts being coated and the applicator. A distance of 1 inch for every 10KV of output voltage is required at all times.</p> <p>Test only in areas free of combustible material. Testing may require high voltage to be on, but only as instructed.</p> <p>Non-factory replacement parts or unauthorized equipment modifications may cause fire or injury. If used, the key switch bypass is intended for use only during setup operations. Production should never be done with safety interlocks disabled.</p> <p>The paint process and equipment should be set up and operated in accordance with NFPA-33, NEC, OSHA, local, country, and European Health and Safety Norms.</p>

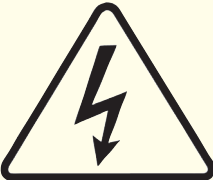
<p><b>AREA</b> Tells where hazards may occur.</p>	<p><b>HAZARD</b> Tells what the hazard is.</p>	<p><b>SAFEGUARDS</b> Tells how to avoid the hazard.</p>
<p><b>Spray Area</b></p> 	<p><b>Explosion Hazard</b></p> <p>Improper or inadequate operation and maintenance procedures will cause a fire hazard.</p> <p>Protection against inadvertent arcing that is capable of causing fire or explosion is lost if any safety interlocks are disabled during operation.</p> <p>Frequent Power Supply or Controller shutdown indicates a problem in the system requiring correction.</p>	<p>Electrostatic arcing must be prevented. Safe sparking distance must be maintained between the parts being coated and the applicator. A distance of 1 inch for every 10KV of output voltage is required at all times.</p> <p>Unless specifically approved for use in hazardous locations, all electrical equipment must be located <b>outside</b> Class I or II, Division 1 or 2 hazardous areas, in accordance with NFPA-33.</p> <p>Test only in areas free of flammable or combustible materials.</p> <p>The current overload sensitivity (if equipped) <b>MUST</b> be set as described in the corresponding section of the equipment manual. Protection against inadvertent arcing that is capable of causing fire or explosion is lost if the current overload sensitivity is not properly set. Frequent power supply shutdown indicates a problem in the system which requires correction.</p> <p>Always turn the control panel power off prior to flushing, cleaning, or working on spray system equipment.</p> <p>Before turning high voltage on, make sure no objects are within the safe sparking distance.</p> <p>Ensure that the control panel is interlocked with the ventilation system and conveyor in accordance with NFPA-33, EN 50176.</p> <p>Have fire extinguishing equipment readily available and tested periodically.</p>
<p><b>General Use and Maintenance</b></p> 	<p>Improper operation or maintenance may create a hazard.</p> <p>Personnel must be properly trained in the use of this equipment.</p>	<p>Personnel must be given training in accordance with the requirements of NFPA-33, EN 60079-0.</p> <p>Instructions and safety precautions must be read and understood prior to using this equipment.</p> <p>Comply with appropriate local, state, and national codes governing ventilation, fire protection, operation maintenance, and housekeeping. Reference OSHA, NFPA-33, EN Norms and your insurance company requirements.</p>

<p><b>AREA</b> Tells where hazards may occur.</p>	<p><b>HAZARD</b> Tells what the hazard is.</p>	<p><b>SAFEGUARDS</b> Tells how to avoid the hazard.</p>
<p><b>Spray Area / High Voltage Equipment</b></p> 	<p><b>Electrical Discharge</b></p> <p>There is a high voltage device that can induce an electrical charge on ungrounded objects which is capable of igniting coating materials.</p> <p>Inadequate grounding will cause a spark hazard. A spark can ignite many coating materials and cause a fire or explosion.</p>	<p>Parts being sprayed and operators in the spray area must be properly grounded.</p> <p>Parts being sprayed must be supported on conveyors or hangers that are properly grounded. The resistance between the part and earth ground must not exceed 1 meg ohm. (Refer to NFPA-33.)</p> <p>Operators must be grounded. Rubber soled insulating shoes should not be worn. Grounding straps on wrists or legs may be used to assure adequate ground contact.</p> <p>Operators must not be wearing or carrying any ungrounded metal objects.</p> <p>When using an electrostatic handgun, operators must assure contact with the handle of the applicator via conductive gloves or gloves with the palm section cut out.</p> <p><b>NOTE: REFER TO NFPA-33 OR SPECIFIC COUNTRY SAFETY CODES REGARDING PROPER OPERATOR GROUNDING.</b></p> <p>All electrically conductive objects in the spray area, with the exception of those objects required by the process to be at high voltage, must be grounded. Grounded conductive flooring must be provided in the spray area.</p> <p>Always turn off the power supply prior to flushing, cleaning, or working on spray system equipment.</p> <p>Unless specifically approved for use in hazardous locations, all electrical equipment must be located <b>outside</b> Class I or II, Division 1 or 2 hazardous areas, in accordance with NFPA-33.</p> <p>Avoid installing an applicator into a fluid system where the solvent supply is ungrounded.</p> <p>Do not touch the applicator electrode while it is energized.</p>

<p><b>AREA</b> Tells where hazards may occur.</p>	<p><b>HAZARD</b> Tells what the hazard is.</p>	<p><b>SAFEGUARDS</b> Tells how to avoid the hazard.</p>
<p><b>Electrical Equipment</b></p> 	<p><b>Electrical Discharge</b></p> <p>High voltage equipment is utilized in the process. Arcing in the vicinity of flammable or combustible materials may occur. Personnel are exposed to high voltage during operation and maintenance.</p> <p>Protection against inadvertent arcing that may cause a fire or explosion is lost if safety circuits are disabled during operation.</p> <p>Frequent power supply shut-down indicates a problem in the system which requires correction.</p> <p>An electrical arc can ignite coating materials and cause a fire or explosion.</p>	<p>Unless specifically approved for use in hazardous locations, the power supply, control cabinet, and all other electrical equipment must be located outside Class I or II, Division 1 and 2 hazardous areas in accordance with NFPA-33 and EN 50176.</p> <p>Turn the power supply OFF before working on the equipment.</p> <p>Test only in areas free of flammable or combustible material.</p> <p>Testing may require high voltage to be on, but only as instructed.</p> <p>Production should never be done with the safety circuits disabled.</p> <p>Before turning the high voltage on, make sure no objects are within the sparking distance.</p>
<p><b>Toxic Substances</b></p> 	<p><b>Chemical Hazard</b></p> <p>Certain materials may be harmful if inhaled, or if there is contact with the skin.</p>	<p>Follow the requirements of the Safety Data Sheet supplied by coating material manufacturer.</p> <p>Adequate exhaust must be provided to keep the air free of accumulations of toxic materials.</p> <p>Use a mask or respirator whenever there is a chance of inhaling sprayed materials. The mask must be compatible with the material being sprayed and its concentration. Equipment must be as prescribed by an industrial hygienist or safety expert, and be NIOSH approved.</p>
<p><b>Spray Area</b></p> 	<p><b>Explosion Hazard — Incompatible Materials</b></p> <p>Halogenated hydrocarbon solvents for example: methylene chloride and 1,1,1,-Trichloroethane are not chemically compatible with the aluminum that might be used in many system components. The chemical reaction caused by these solvents reacting with aluminum can become violent and lead to an equipment explosion.</p>	<p>Spray applicators require that aluminum inlet fittings be replaced with stainless steel.</p> <p>Aluminum is widely used in other spray application equipment - such as material pumps, regulators, triggering valves, etc. Halogenated hydrocarbon solvents must never be used with aluminum equipment during spraying, flushing, or cleaning. Read the label or data sheet for the material you intend to spray. If in doubt as to whether or not a coating or cleaning material is compatible, contact your coating supplier. Any other type of solvent may be used with aluminum equipment.</p>



# INTRODUCTION

## FEATURES

- Two independently controlled flow pressure ranges.
- High flow range port for higher fluid deliveries.
- Low flow range for more precise control over lower fluid deliveries.
- Interchangeable low flow ratios (1:1, 1:2, 1:3, 1:4, 1:6, 1:8, 1:10) for precise control.
- Stainless steel and coated wetted parts for decreased color change time.

## SPECIFICATIONS

### Environmental/Physical

<b>Height:</b>	1-7/8-inch (48mm)
<b>Height W/Fittings:</b>	2-1/8-inch (54mm)
<b>Diameter:</b>	2-3/4-inch (70mm)
<b>Diameter W/Fittings:</b>	3-3/8-inch (86mm)

### Mechanical

<b>Air Pressures:</b>	Variable by Control (Manual or Automatic) 100 psi (7 bar max.)
<b>Fluid Input:</b>	300 psi (20.7 bar max.) (10 psi minimum above output pressure)
<b>Fluid Output:</b>	Variable by Ratio

#### Pneumatic / Fluid Connections

<b>Air Pilot:</b>	#10-32 Thread (Low & High)
<b>Fluid In:</b>	1/4-inch NPSM Thread
<b>Fluid Out:</b>	1/8-inch NPSM Thread 3/16-inch OD Tubing, use 70589-04 Fitting 1/4-inch OD Tubing, use 70589-05 Fitting 3/8-inch OD Tubing, use 70589-10 Fitting 6mm OD Tubing, use 70589-06 Fitting 8mm OD Tubing, use 70589-11 Fitting 3/8-inch NPSM Hose Connection, use 70589-12 Fitting

<b>Volume of Paint Held Within Regulator:</b>	5 cc
---	------

### DR-1 FLOW VS SIGNAL PRESSURE

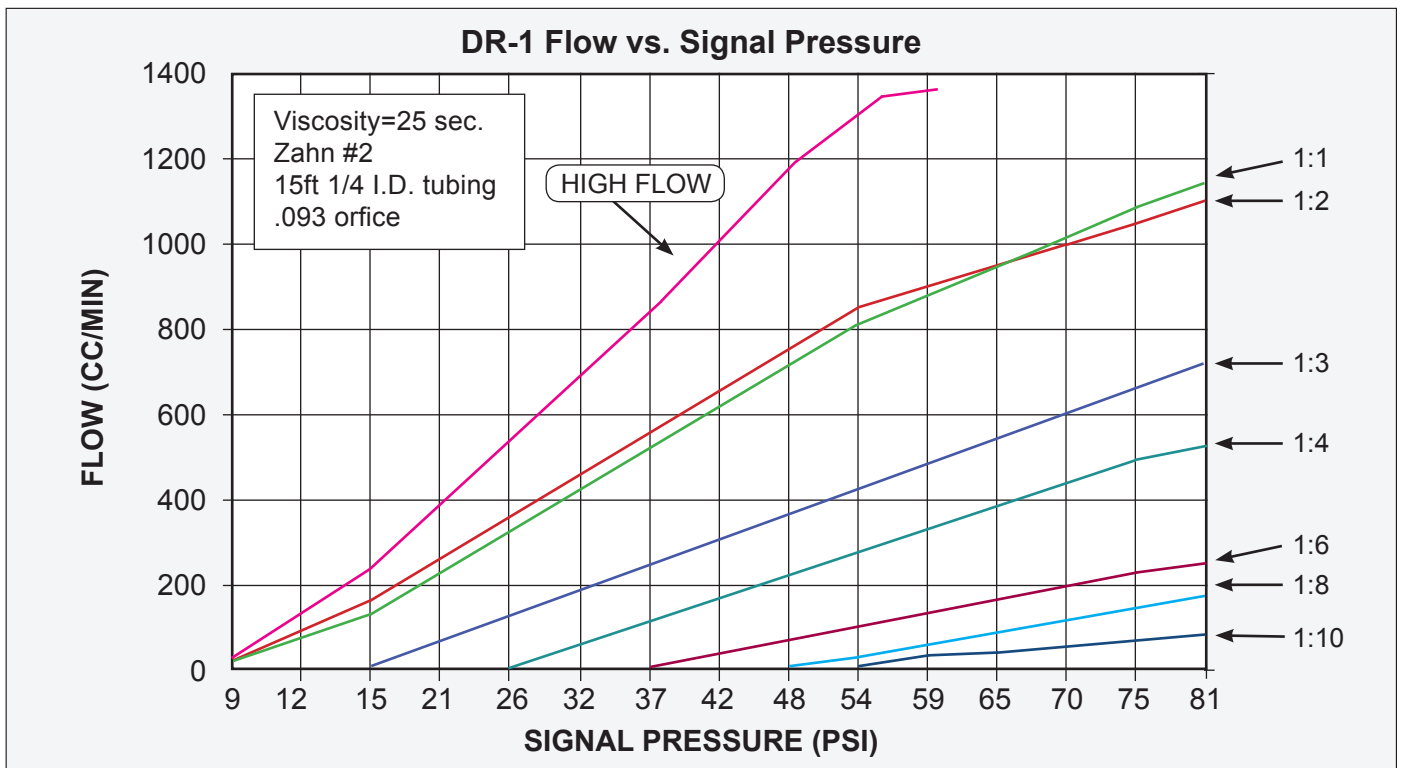
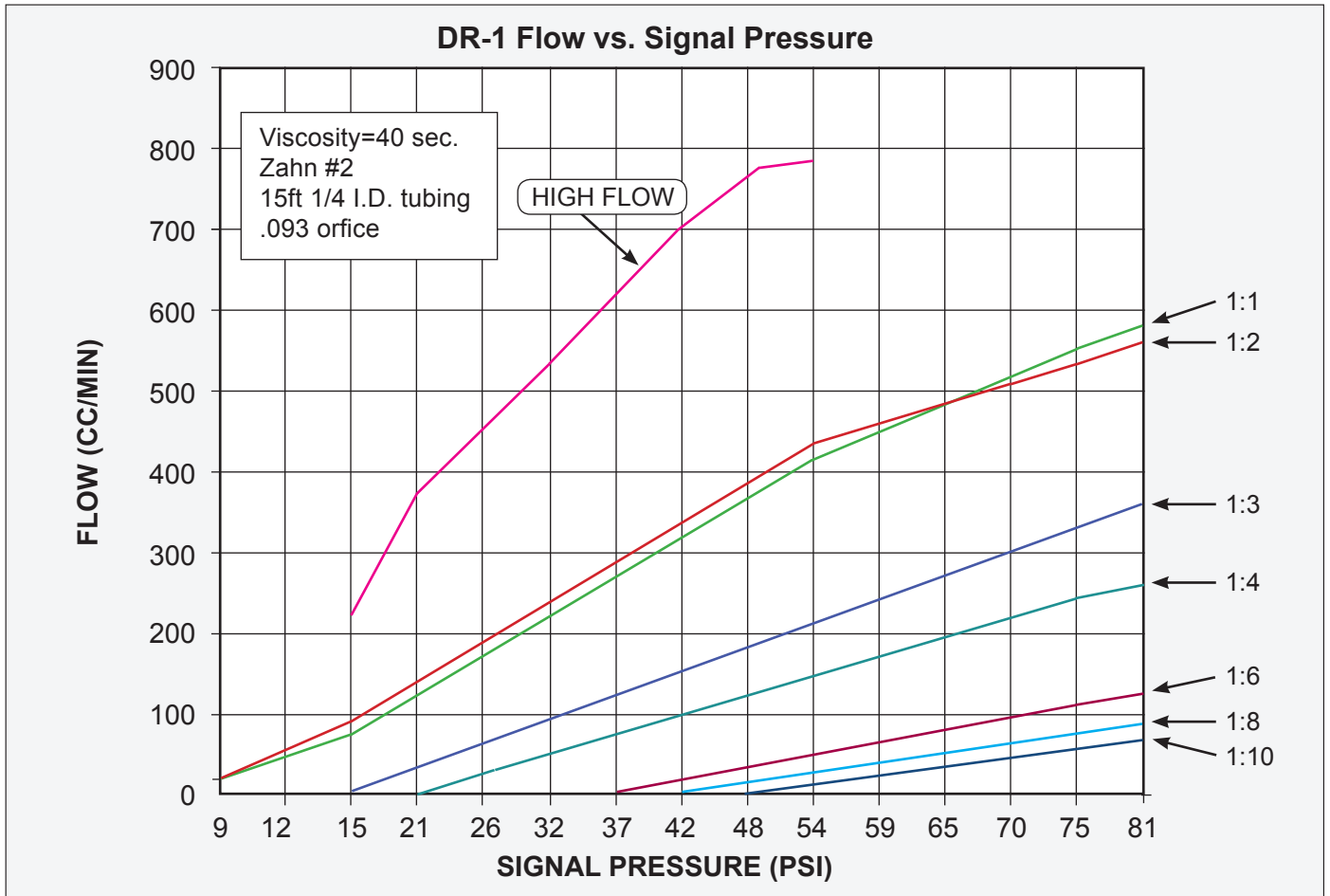

# OPERATION

The DR-1 Regulator is designed to provide remote control fluid regulation for automatic coating applications.

The regulator features two independently controllable flow pressure ranges from the fluid output port. The high flow range port accommodates higher fluid deliveries and minimal color change times. The lower flow ranges provide precise fluid delivery control. There are seven lower range models available (1:1, 1:2, 1:3, 1:4, 1:6, 1:8, and 1:10) which can be selected based on the required fluid flow rate.

Separate pilot signals modulate each of the regulator's two diaphragms to control the amount of paint being delivered from the regulator to the spray applicator.

Because of the regulator's dual range capabilities, it provides the user flexibility for selecting either the high flow range or the low flow range. Different coating material viscosities and quick color change requirements may necessitate the use of both ranges. If color change time is not a factor or if material viscosity remains relatively constant, either port may be used depending on flow rate requirements. All regulators, regardless of ratio designation, have the high flow port.

The low flow (i.e. 1:2, 1:4, etc.) port provides a lower, more precise flow response curve. Fluid output, as a result, is less likely to be affected by pilot signal errors. An increase in the ratio (i.e. from 1:2 to 1:4) provides a lower slope in the flow/air signal pressure curve, but a more precise response curve. This same increase in ratio however, will reduce flow capacity and should be considered when selecting the proper regulator ratio.

The following factors must then be considered when selecting the regulator ratio required for proper fluid control:

- Fluid tubing inside diameter (ID) and length
- Fluid feed tube inside diameter (ID) and length
- Fluid viscosity
- Fluid input pressures

Preliminary testing will determine which regulator ratio should be used. If conditions change after installation which require a different low flow ratio, this regulator can be easily altered by replacing the existing ratio spacer ring and upper retainer with the desired ratio (ratio designation is etched on the side of the spacer ring).



## WARNING

- **NEVER** wrap the applicator, associated valves and tubing, and supporting hardware in plastic to keep it clean. A surface charge may build up on the plastic surface and discharge to the nearest grounded object. Efficiency of the applicator will also be reduced and damage or failure of the applicator components may occur. **WRAPPING THESE COMPONENTS IN PLASTIC WILL VOID WARRANTY.**

# MAINTENANCE

## TOOLS REQUIRED

- 3/8", 7/16", 7/8", and 15/16" Open-End Wrenches
- 5/32" Allen Head Wrench
- Adjustable Wrench
- Screwdriver
- Repair Kit, 73913-00 or 73913-01

## PRELIMINARY PROCEDURES

Prior to removing the regulator for service or repair, perform the following:

1. If possible, flush the regulator with suitable cleaning solvent.
2. Turn the fluid and air "OFF" to the regulator and disconnect the air and fluid lines from the regulator.
3. Remove the regulator for service.

## DISASSEMBLY PROCEDURES (Refer to Figure 1)

### NOTE

- Unless replacing Item 1 (cap) and/or Item 2 (spacer ring), it is **NOT** necessary to remove Item 18 (air fitting) and Item 15 (gasket).
- Item 11 (regulating needle and seat) is a matching set with matching serial numbers. Care must be taken to not use needles and seats with non-matching serial numbers as fluid leakage may occur. If either component needs to be replaced, a new matched set must be used.

1. Remove Item 4 (8 screws) holding the regulator assembly together with the 5/32" Allen wrench.

2. Remove Item 1 (cap), Item 9 (upper diaphragm), Item 2 (spacer ring), and Item 3 (lower housing assembly). This will leave the diaphragm assembly Item 5 (upper diaphragm retainer), Item 14 (center diaphragm), Item 7 (center diaphragm retainer), Item 17 (bleed spacer), Item 8 (lower diaphragm), Item 10 (o-ring), and Item 6 (lower diaphragm retainer) held together by Item 16 (screw).

### CAUTION

- When separating parts it may be necessary to use a small screwdriver. Care should be taken to **NOT** damage the components. Damage of these parts may cause leakage.

3. With a screwdriver, remove Item 16 (screw) from the diaphragm assembly.
4. Separate Item 6 (lower diaphragm retainer), Item 10 (o-ring), Item 8 (lower diaphragm), Item 17 (bleed spacer), Item 14 (center diaphragm), and Item 5 (upper diaphragm retainer).
5. With the 7/8" and the 15/16" open-end wrenches, remove Item 13 (retaining plug), Item 12 (spring,) and Item 11 (regulating needle) from Item 3 (lower housing).
6. Remove Item 11 (regulating seat) and Item 10 (o-ring) from the lower housing assembly.
7. Clean all metal parts with suitable cleaning solvent. **DO NOT** use solvent on the diaphragms or o-rings.

### CAUTION

- Care **MUST** be taken while cleaning the coated parts of the regulator to prevent scratching.

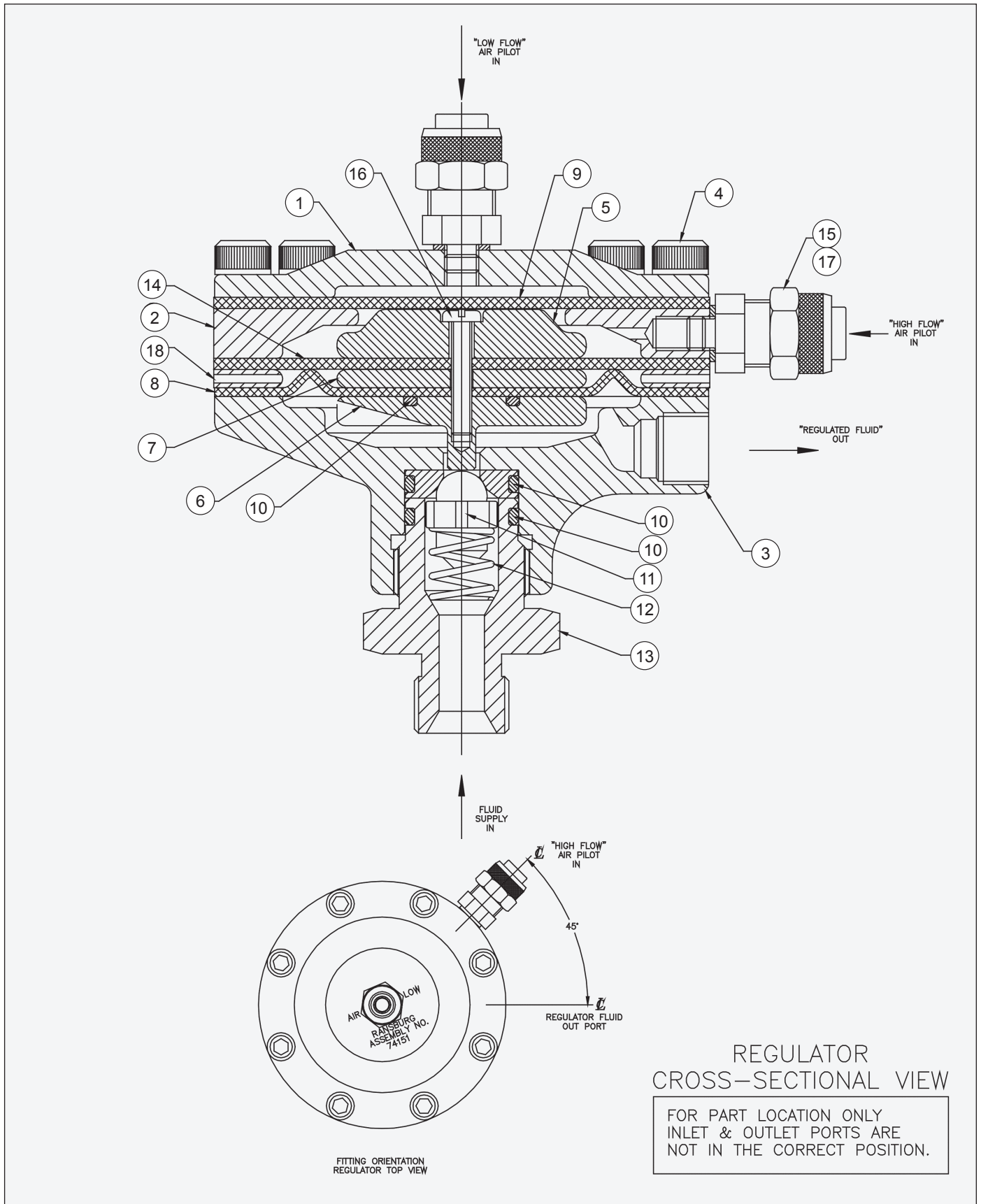

Figure 1: Regulator Cross-Sectional View

## ASSEMBLY PROCEDURES

(Refer to Figure 1)

1. Inspect Item 11 (regulating needle and seat) for damage. If either of these items are damaged or the mating surfaces are scratched, both items should be replaced as a matching set.

2. Discard the following items and replace them with the new item from the 73913-00 or 73913-01 repair kit:

- Item 16 Screw
- Item 10 O-Ring
- Item 9 Upper Diaphragm
- Item 14 Center Diaphragm
- Item 8 Lower Diaphragm

3. Place Item 10 (o-ring) in the slot on Item 6 (lower diaphragm retainer).

4. Place Item 8 (lower diaphragm) on Item 6 (lower diaphragm retainer) with the side of the diaphragm contacting the retainers (o-ring side).

5. Stack the following parts on Item 8 (lower diaphragm), in the following order:

- Item 7 (Center Diaphragm Retainer)
- Item 18 (Bleed Spacer)
- Item 14 (Center Diaphragm)
- Item 5 (Upper Diaphragm Retainer)
- Item 16 (Screw)

6. Ensure that clearance holes in Items 8 and 14 (diaphragms) and Item 17 (bleed spacer) are aligned properly and tighten Item 16 (screw). Use adhesive 222 on screw threads. Set the diaphragm assembly aside.

7. Place Item 3 (lower housing) on table with bottom threaded opening facing "UP".

8. Insert Item 10 (o-ring) onto Item 11 (regulating seat) and then insert the assembly into Item 3 (lower housing). The beveled side of the regulating seat must be "UP".

### CAUTION

- **DO NOT** scratch the coating.

9. Place Item 11 (regulating needle) into Item 3 (lower housing) with the ball end against Item 11 (regulating seat).

10. Place Item 10 (o-ring) on Item 13 (retaining plug).

### NOTE

- Apply a small amount of non-silicone lubricant to Item 10 (o-ring) prior to assembly.

11. Place Item 12 (spring) into Item 3 (lower housing) over Item 11 (regulating needle) and thread Item 13 (retaining plug) into Item 3 (lower housing). Tighten

### CAUTION

- Verify regulator seat and needle have matching serial numbers.

Item 13 (retaining plug) to 25-30 lbs•ft, ensuring that Item 11 (regulating needle) and Item 12 (spring) remain in the center of Item 3 (lower housing).

12. Place Item 3 (lower housing) on table with bowl facing "UP" and place diaphragm assembly (from step 4) into bowl of Item 3 (lower housing), with pin of Item 6 (lower diaphragm retainer) facing "DOWN". Rotate the diaphragm assembly so that the slot on Item 6 (lower retainer) is 180° to the outlet port of Item 3 (lower housing) for cleaner flushing of the regulator assembly.

13. Place Item 2 (spacer ring) on the top of Item 14 (center diaphragm) with largest opening facing "DOWN". Rotate Item 2 (spacer ring), without rotating the diaphragm assembly, so that the air pilot port of Item 2 (spacer ring) is 45° to the outlet port of Item 3 (lower housing) and all the clearance holes are aligned (see Figure 1).

14. Place Item 9 (upper diaphragm) on Item 2 (spacer ring) and align holes.

15. Place Item 1 (cap) on Item 9 (upper diaphragm). Align holes and insert Item 4 (8 screws).

16. Tighten opposing screws alternately to 10 lbs•in, ensuring uniform sealing of the diaphragms. Then follow by tightening each screw in a circle pattern to 20 lbs•in.
17. If Item 15 (air fittings) were removed from either Item 2 (spacer ring) or Item 1 (cap), screw them along with Item 18 (gasket) back onto these items.

### CAUTION

➤ **DO NOT** overtighten the air fittings. Overtightening the fittings may cause the stem of the fitting to snap off.

### NOTE

➤ If water or solvent is used for testing, it is normal for minor leakage to occur at the fluid output port, due to the low viscosities of these fluids.

4. Gradually increase air pressure on either of the air lines and visually observe a gradual increase in fluid flow. If regulator does not perform satisfactorily, inspect components for damage and replace where required.

## TEST PROCEDURES

### (Refer to Figure 1)

After repair is complete, test the regulator in the following manner:

1. Set air and fluid regulators to zero and attach air and fluid lines to the regulator.
2. Gradually increase air pressure to the regulator to 80 psi, visually checking for leaks. Tighten Item 4 (screws) if leakage occurs.
3. Set air regulator to zero. Gradually increase fluid pressure to 80 psi, visually checking for leakage. Clean or replace Item 11 (needle and seat) if leakage at outlet port.

## PREVENTIVE MAINTENANCE

1. Rebuild with 73913, Repair Kit, and 74160-00, needle and seat, at 6 months minimum, 12 months maximum.
2. Re-torque eight (8) screws at the following intervals:
  - 2 days after rebuild
  - Immediately before installation
  - 6 month intervals



## TROUBLESHOOTING GUIDE

General Problem	Possible Cause	Solution
<b>No Fluid Flow</b>	Plugged fluid inlet	Flush clean.
	Item 11 (regulating needle and seat) stuck	Remove and clean or replace.
	No pilot air	Check air pilot signal.
	Ruptured Item 9 (upper diaphragm)	Rebuild regulator.
	Ruptured Item 14 (center diaphragm)	Rebuild regulator.
<b>Fluid Will Not Shut Off</b>	Dirt in Item 11 (regulating needle/seat)	Remove and clean or replace. (Must be replaced as a set, see "Maintenance" section.)
	Pilot air not shut off	Check signal air supply.
	Broken Item 12 (spring)	Replace item 12 (spring).
<b>Paint Leakage</b>	Item 4 (screws) loose	Tighten per "Assembly Procedure" in the "Maintenance" section.
	Ruptured Item 8 (lower diaphragm)	Rebuild regulator.
	Item 13 (retaining plug) loose	Tighten, torque to 25-30 lbs•ft (see "Maintenance" section).
	Loose fluid fitting	Tighten.
	Item 10 (o-ring) pinched	Replace Item 10 (o-ring).
<b>Air Leakage</b>	Loose air fitting	Tighten.
	Item 4 (screws) loose	Tighten.
	Ruptured Item 9 (upper diaphragm)	Rebuild regulator.
	Ruptured Item 14 (center diaphragm)	Rebuild regulator.
<b>Low Fluid Flow</b>	Incorrect regulator ratio	Refer to "Operations" section for correct sizing information.
	Fluid supply pressure to low.	Increase fluid supply pressure. (Do not exceed 100 psig (see "Specifications" in the "Introduction" section).
	Air pilot to low.	Check air pilot signal.

(Continued On Next Page)





## TROUBLESHOOTING GUIDE (Cont.)

General Problem	Possible Cause	Solution
<b><i>Inconsistent Fluid Flow</i></b>	Item 8 (lower diaphragm) stretched from excessive air pilot signal	Rebuild regulator.
	Ruptured Item 9 (upper diaphragm)	Rebuild regulator.
	Ruptured Item 14 (center diaphragm)	Rebuild regulator.
	Inconsistent air pilot	Check pilot air supply.
	Inconsistent fluid supply pressure	Check fluid supply.
<b><i>High Fluid Flow</i></b>	Incorrect regulator ratio	Refer to "Operations" section for correct sizing information.
	Fluid supply pressure too high	Lower fluid supply pressure.

# PARTS IDENTIFICATION

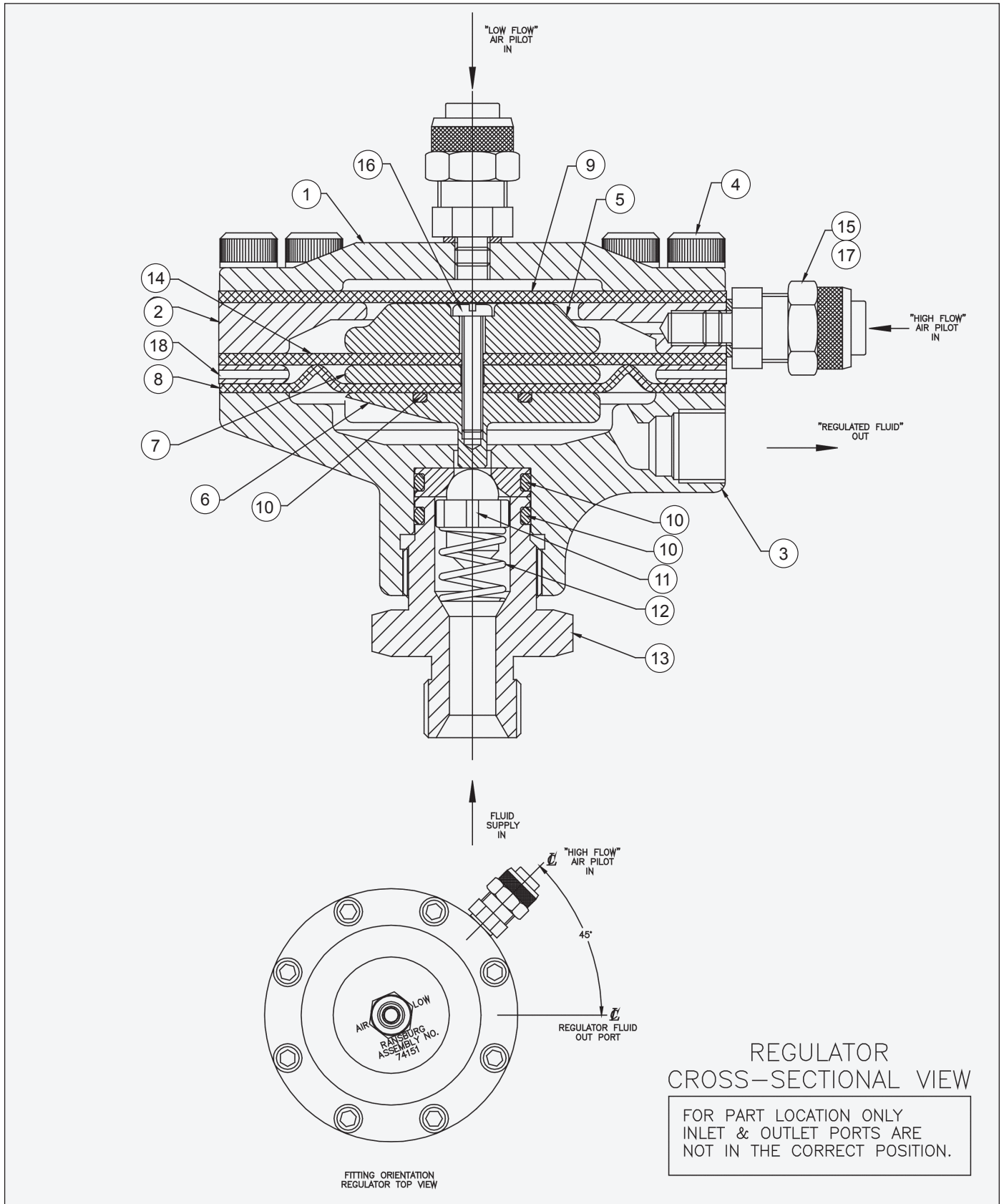

Figure 2: Regulator Cross-Sectional View

### DR-1 FLUID REGULATOR - PARTS LIST (Figure's 1 & 2)

Item #	Description	Part #	Qty
	<b>DR-1 Regulator Assembly</b>	<b>Select Options Below</b>	
	Ratio 1:1	74151-11	
	Ratio 1:2	74151-01	
	Ratio 1:3	74151-06	
	Ratio 1:4	74151-02	
	Ratio 1:6	74151-03	
	Ratio 1:8	74151-04	
	Ratio 1:10	74151-05	
1	Cap	74152-00	1
2	<b>Spacer Ring, For:</b>	<b>Select Options Below</b>	1
	Ratio 1:1	74153-11	
	Ratio 1:2	74153-01	
	Ratio 1:3	74153-06	
	Ratio 1:4	74153-02	
	Ratio 1:6	74153-03	
	Ratio 1:8	74153-04	
	Ratio 1:10	74153-05	
3	Lower Housing	74154	1
4	Screw, Socket Head Cap	8212-28F	8
5	<b>Upper Diaphragm Retainer, For:</b>	<b>Select Options Below</b>	1
	Ratio 1:1	74155-00	
	Ratio 1:2	75374-01	
	Ratio 1:3	75374-06	
	Ratio 1:4	75374-02	
	Ratio 1:6	75374-03	
	Ratio 1:8	74155-00	
	Ratio 1:10	74155-01	
6	Diaphragm Retainer, Lower	74156-00	1
7	Diaphragm Retainer, Center	74231-00	1
8*	Diaphragm, Lower	74273-00	1
9*	Diaphragm, Upper	74157-03	1
10*	<b>O-Ring</b>	<b>Select Options Below</b>	3
	.489" ID x .070" c/s, Solvent Resistant	7554-11	
	.489" ID x .070" c/s, Solvent Proof	79001-08 (Optional)	
11	Needle & Seat, Regulating	74160-00	1
12	Spring	74161-00	1
13	Retaining Plug	74162-00	1
14*	Diaphragm, Center	74157-04	1
15	Fitting, Air	7892-12	2

\* Parts contained in Repair Kit

(Continued On Next Page)

### DR-1 FLUID REGULATOR - PARTS LIST (Figure's 1 & 2) (Cont.)

Item #	Description	Part #	Qty
16*	Screw, Pan Head	74183-20C	1
17	Gasket	72135-00	2
18	Bleed Spacer	74232-00	1
20	<b>Paint Fitting (not included), For:</b>	<b>Select Options Below</b>	
	3/16" OD Tubing	70589-04	
	1/4" OD Tubing	70589-05	
	3/8" OD Tubing	70589-10	
	6mm OD Tubing	70589-06	
	8mm OD Tubing	70589-11	
	3/8" NPSM Hose Connection	70589-12	

\* Parts contained in Repair Kit

### RECOMMENDED SPARE PARTS

Part #	Description	Qty
74156-00	Diaphragm Retainer, Lower	1
74160-00	Needle and Seat, Regulating	1
74161-00	Spring	1

### SERVICE KITS

Part #	Description
73913-00	Repair Kit, W/Solvent Resistant O-Rings
73913-01	Repair Kit, W/Solvent Proof O-Rings

# MANUAL CHANGE SUMMARY

**LN-9223-00-R12** - Replaces LN-9223-00.11 with the following changes:

No.	Change Description	Page(s)
1.	Change to new format design	All Pages
2.	New Image	Cover

## WARRANTY POLICY

This product is covered by Carlisle Fluid Technologies materials and workmanship limited warranty. The use of any parts or accessories, from a source other than Carlisle Fluid Technologies, will void all warranties. For specific warranty information please contact Carlisle Fluid Technologies.

Carlisle Fluid Technologies is a global leader in innovative finishing technologies. Carlisle Fluid Technologies reserves the right to modify equipment specifications without prior notice.

DeVilbiss®, Ransburg®, MS®, BGK®, and Binks®,  
are registered trademarks of Carlisle Fluid Technologies, Inc.

©2018 Carlisle Fluid Technologies, Inc.  
All rights reserved.

For technical assistance or to locate an authorized distributor, contact one of our international sales and customer support locations.

<b>Region</b>	<b>Industrial / Automotive</b>	<b>Automotive Refinishing</b>
<b>Americas</b>	Tel: 1-800-992-4657 Fax: 1-888-246-5732	Tel: 1-800-445-3988 Fax: 1-800-445-6643
<b>Europe, Africa Middle East, India</b>	Tel: +44 (0)1202 571 111 Fax: +44 (0)1202 573 488	
<b>China</b>	Tel: +8621-3373 0108 Fax: +8621-3373 0308	
<b>Japan</b>	Tel: +81 45 785 6421 Fax: +81 45 785 6517	
<b>Australia</b>	Tel: +61 (0) 2 8525 7555 Fax: +61 (0) 2 8525 7575	

For the latest information about our products, visit [www.carlisleft.com](http://www.carlisleft.com).