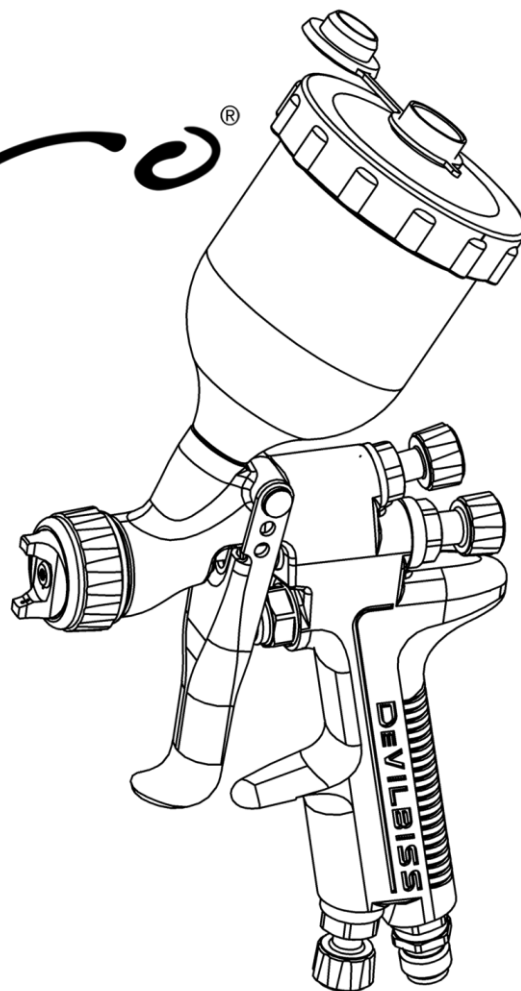

**DEVILBISS****DEVILBISS Sri PRO  
Series: SRi PRO Lite****Gravity Spray Gun for micro, smart repairs and  
small areas.**CE  II 2 G X**SRi PRO<sup>®</sup>  
LITE****IMPORTANT! DO NOT DESTROY**

It is the Customer's responsibility to have all operators and service personnel read and understand this manual.

Contact your local DeVilbiss representative for additional copies of this manual.

**READ ALL INSTRUCTIONS BEFORE OPERATING THIS DEVILBISS PRODUCT.**

## FUNCTIONAL DESCRIPTION

EN

The SRi PRO Lite spray gun is a professional quality gun designed with EPA compliant, high efficiency or high volume, low pressure (HVLP) technology. HVLP technology reduces overspray and limits air cap pressure to 0.7 bar [10 psi]. High efficiency complies with EPA by obtaining transfer efficiency above 65%.  
IMPORTANT: This spraygun is suitable for use with both waterbased and solvent based coating materials. The gun is not designed for use with highly corrosive and/or abrasive materials and if used with such materials it must be expected that the need for cleaning and/or replacement of parts will be increased. If there is any doubt regarding the suitability of a specific material, contact your DeVilbiss Distributor or DeVilbiss direct.

## SPECIFICATIONS

AIR INLET PRESSURES	
P1 = Max Static Air Input Pressure	12 bar [175 psi]
Gun Air Inlet Pressure for High Efficiency and HVLP setups, with gun triggered.	2.0 bar [29 psi]
Vibration Level:	<2.5 m/s <sup>2</sup>
Sound Power Level:	Available on request
Sound Pressure Level:	Available on request

ENVIRONMENTAL	
Max Ambient Operating Temperature	WITH CUP

MATERIALS OF CONSTRUCTION	
Gun Body, Air Cap Retaining Ring, Knobs	Anodised Aluminium
Air Cap	Nickel plated brass
Fluid Tip, Fluid Needle and Trigger Stud	Stainless Steel
Springs, Clips, Screws	Stainless Steel
Seals, Gaskets	Solvent resistant
Trigger	Chrome plated steel
Air Inlet, Body Bushing, Spreader Valve Body, Air Valve Nut	Chrome plated brass
Air Valve Assembly	Stainless Steel, HDPE

CONNECTIONS	
Air Inlet Size	Universal 1/4" BSP and 1/4" NPS male
Fluid Inlet Size	7/16" - 14 UNC

WEIGHT	
GUN ONLY	395g
WITH CUP	455g

DIMENSIONS	
L x H x W mm	135 x 252 x 18

**Product Description / Object of Declaration:**    **SRI PRO LITE**



**This Product is designed for use with:**                      Solvent and water based materials

**Suitable for use in hazardous area:**                              Zone 1 / Zone 2

**Protection Level:**    II 2 G X

**Notified body details and role:**                                      TRAC Global Ltd (0891)  
Lodging of Technical file

**This Declaration of conformity /  
incorporation is issued under the sole  
responsibility of the manufacturer:**                              Finishing Brands UK Ltd,  
Ringwood Road,  
Bournemouth, BH11 9LH. UK

<h2>EU Declaration of Conformity</h2> <p><b>The object of the declaration described above is in conformity with the relevant Union harmonisation legislation:</b></p> <p>Machinery Directive 2006/42/EC ATEX Directive 2014/34/EU by complying with the following statutory documents and harmonised standards: EN ISO 12100:2010 Safety of Machinery - General Principles for Design BS EN 1953:2013 Atomising and spraying equipment for coating materials - Safety requirements EN 1127-1:2011 Explosive atmospheres - Explosion prevention - Basic concepts EN 13463-1:2009 Non electrical equipment for use in potentially explosive atmospheres - Basic methods and requirements HVLV and High Efficiency products comply with the requirements of PG6 from the EPA guidelines and offer greater than 65% transfer efficiency.</p> <p>Providing all conditions of safe use / installation stated within the product manuals have been complied with and also installed in accordance with any applicable local codes of practice.</p> <p>Signed for and on behalf of Finishing Brands UK Ltd:  D Smith                      Director of Sales (EMEA) 30/8/16</p>	 
---	---

⚠ <b>WARNING</b>	⚠ <b>CAUTION</b>	⚠ <b>NOTE</b>
Hazards or unsafe practices which could result in severe personal injury, death or substantial property damage.	Hazards or unsafe practices which could result in minor personal injury, product or property damage.	Important installation, operation or maintenance information.
⚠ <b>WARNING</b>		

Read the following warnings before using this equipment.



**SOLVENTS AND COATING MATERIALS.** Can be highly flammable or combustible when sprayed. Always refer to the coating material supplier's instructions and safety sheets before using this equipment.



**INSPECT THE EQUIPMENT DAILY.** Inspect the equipment for worn or broken parts on a daily basis. Do not operate the equipment if you are uncertain about its condition.



**READ THE MANUAL.** Before operating finishing equipment, read and understand all safety, operation and maintenance information provided in the operation manual. Users must comply with all local and national codes of practice and insurance company requirements governing ventilation, fire precautions, operation and house-keeping of working areas.



**EQUIPMENT MISUSE HAZARD.** Equipment misuse can cause the equipment to rupture, malfunction or start unexpectedly and result in serious injury.



**FIRE AND EXPLOSION HAZARD.** Never use 1,1,1-Trichloroethane, Methylene Chloride, other Halogenated Hydrocarbon solvents or fluids containing such solvents in equipment with aluminium wetted parts. Such use could result in a serious chemical reaction, with the possibility of explosion. Consult your fluid suppliers to ensure that the fluids being used are compatible with aluminium parts.



**GLOVES.** Must be worn when spraying or cleaning the equipment.



**WEAR SAFETY GLASSES.** Failure to wear safety glasses with side shields could result in serious eye injury or blindness.



**STATIC CHARGE.** Fluid may develop a static charge that must be dissipated through proper grounding of the equipment, objects to be sprayed and all other electrically conductive objects in the dispensing area. Improper grounding or sparks can cause a hazardous condition and result in fire, explosion or electric shock and other serious injury.



**WEAR RESPIRATOR.** The use of respiratory protective equipment is recommended at all times. The type of equipment must be compatible with the material being sprayed.



**TOXIC VAPOURS.** When sprayed, certain materials may be poisonous, create irritation, or are otherwise harmful to health. Always read all labels, safety sheets and follow any recommendations for the material before spraying. If in doubt contact your material supplier.



**NEVER MODIFY THE EQUIPMENT.** Do not modify the equipment unless the manufacturer provides written approval.



**LOCK OUT / TAG-OUT.** Failure to de-energise, disconnect, lock out and tag-out all power sources before performing equipment maintenance could cause serious injury or death.

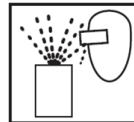

**PROJECTILE HAZARD.** You may be injured by venting liquids or gases that are released under pressure, or flying debris.



**NOISE LEVELS.** The A-weighted sound level of pumping and spray equipment may exceed 85 dB(A) depending on equipment settings. Actual noise levels are available on request. It is recommended that ear protection is worn at all times while equipment is in use.



**PRESSURE RELIEF PROCEDURE.** Always follow the pressure relief procedure in the equipment instruction manual.



**KNOW WHERE AND HOW TO SHUT OFF THE EQUIPMENT IN CASE OF AN EMERGENCY.**



**HIGH PRESSURE CONSIDERATION.** High pressure can cause serious injury. Relieve all pressure before servicing. Spray from the gun, hose leaks or ruptured components can inject fluid into your body and cause extremely serious injury.



**OPERATOR TRAINING.** All personnel must be trained before operating finishing equipment.

**IT IS THE RESPONSIBILITY OF THE EMPLOYER TO PROVIDE THIS INFORMATION TO THE OPERATOR OF THE EQUIPMENT.**

**GUN PART NUMBER FORMAT & PART SELECTION GUIDE**

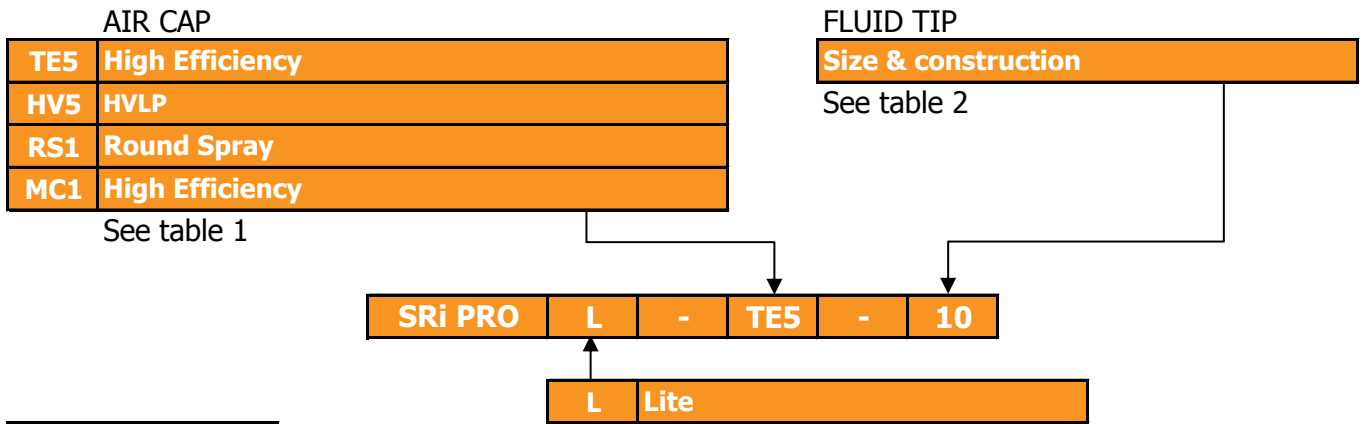

**TABLE 1**

**AIR CAP PERFORMANCE GUIDE**

Air Cap & Type		Part Number	Air Consumption (L/Min)	Recommended Air Inlet Pressure	Typical Fluid Flow*	Typical Fan Pattern Size**
TE5	High Efficiency	SRIPRO-102-TE5-K	100 [3.5 cfm]	2 Bar [29 psi]	5 - 100 ml/min	180mm
HV5	HVLP	SRIPRO-102-HV5-K	135 [4.8 cfm]	2 Bar [29 psi]	5 - 80 ml/min	160mm
RS1	Round Spray	SRIPRO-102-RS1-K	55 [1.9 cfm]	2 Bar [29 psi]	5 - 50 ml/min	50mm
MC1	High Efficiency	SRIPRO-102-MC1-K	50 [1.8 cfm]	1 Bar [14.5 psi]	1 - 50 ml/min	60mm

\* Flow rates may vary according to paint/material and pressure used.

\*\* Fan pattern size @ 50 - 100mm distance.

**TABLE 2**

**FLUID TIPS & NEEDLES**

Fluid Tip Size	Stainless Steel	
	Fluid Tip	Needle
06	SRIPRO-210-06M-K	SRIPRO-310-06M-K
08	SRIPRO-200-08-K	SRIPRO-300-08-10-K
10	SRIPRO-200-10-K	SRIPRO-300-08-10-K
12	SRIPRO-200-12-K	SRIPRO-300-12-14-K
14	SRIPRO-200-14-K	SRIPRO-300-12-14-K

**TABLE 3**

**RECOMMENDED FLUID TIP / AIR CAP COMBINATIONS**

Air Cap & Type		0.6mm	0.8mm	1.0mm	1.2mm	1.4mm
TE5	High Efficiency	-	S	S	S	S
HV5	HVLP	-	S	S	S	S
RS1	Round Spray	-	S	S	S	S
MC1	High Efficiency	S	-	-	-	-

S= High quality stainless steel tips & needles available in this type & size.

EXPLODED VIEW

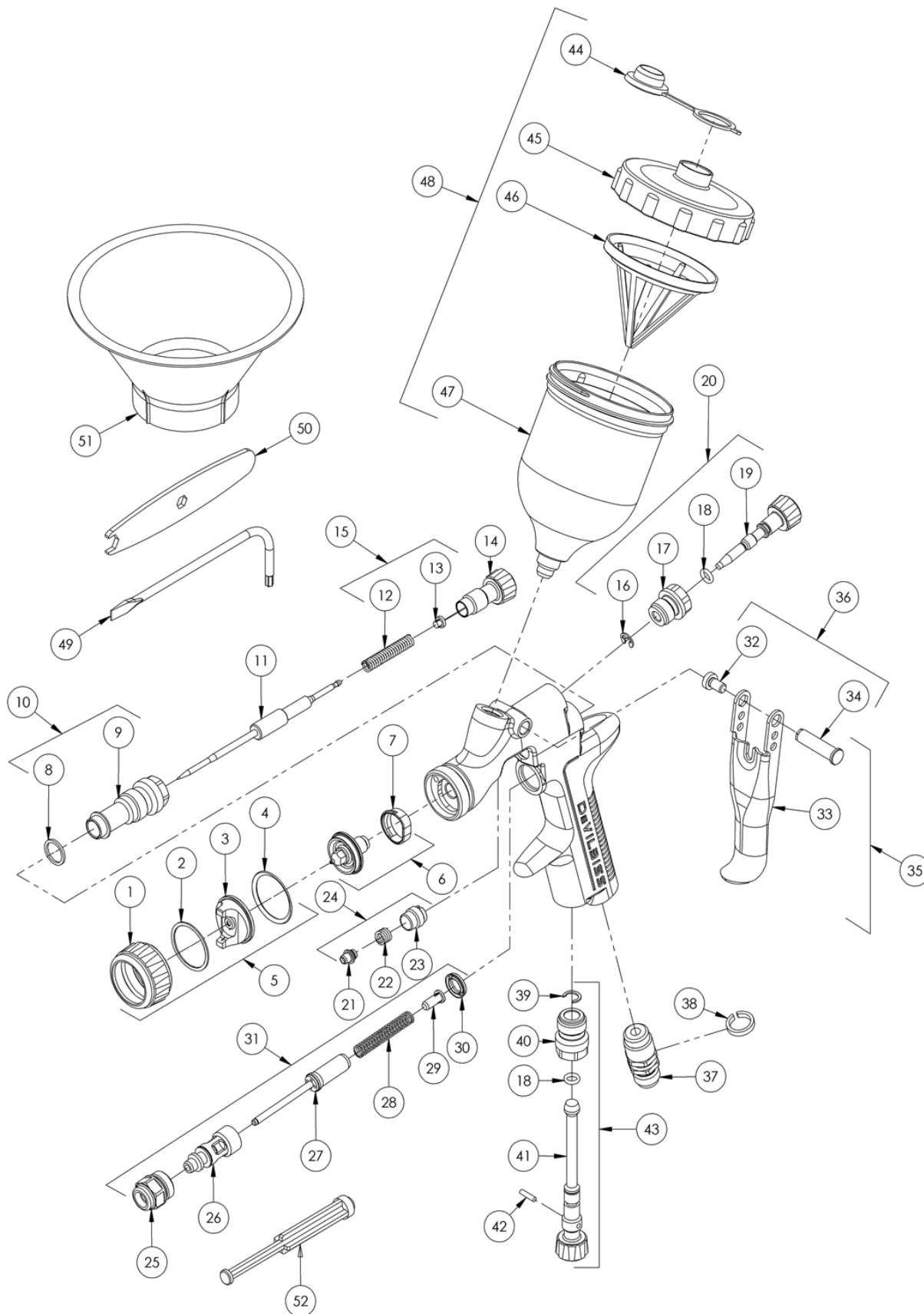

## PARTS LIST

REF.	PART No.	DESCRIPTION	QTY.
1	-	RETAINING RING	1
2	-	SLIP RING	1
3	-	AIR CAP	1
4	-	RETAINING RING SEAL	1
5	SEE TABLE 1	AIR CAP & RETAINING RING	1
6	SEE TABLE 2	FLUID TIP & SEPARATOR	1
*7	SRIPRO-2-K5	SEPARATOR (KIT OF 5)	1
*8	-	BODY BUSHING SEAL	1
9	-	BODY BUSHING	1
10	SN-6-K	BODY BUSHING & SEAL	1
11	SEE TABLE 2	FLUID NEEDLE	1
*12	-	NEEDLE SPRING	1
*13	-	NEEDLE SPRING PAD	1
14	SN-81-K	FLUID ADJUSTING KNOB	1
15	SN-423-K3	SPRING & PAD (KIT OF 3)	1
16	-	CIRCLIP	1
17	-	SPREADER VALVE BODY	1
*18	-	SPREADER VALVE SEAL	2
19	-	SPREADER VALVE ADJUSTING KNOB	1
20	SRIPRO-402-K	SPREADER VALVE ASSEMBLY	1
21	-	NEEDLE PACKING	1
22	-	PACKING SPRING	1
23	-	PACKING NUT	1
*24	SN-404-K	PACKING, SPRING & PACKING NUT KIT	1
25	-	AIR VALVE BODY	1
26	-	AIR VALVE CAGE	1
27	-	AIR VALVE POPPET	1
28	-	AIR VALVE SPRING	1
29	-	AIR VALVE SPRING PAD	1
30	-	AIR VALVE SEAL	1
31	SN-402-K	AIR VALVE ASSEMBLY	1
*32	-	TRIGGER STUD SCREW (T20 TORX)	1
33	-	TRIGGER	1
*34	-	TRIGGER STUD	1
35	SN-42-K	TRIGGER STUD & SCREW KIT	1
36	SN-405-K5	STUD AND SCREW KIT (KIT OF 5)	1
37	-	AIR INLET KIT	1

**PARTS LIST (Continued)**

REF.	PART No.	DESCRIPTION	QTY.
38	-	COLOUR ID RING KIT (4 COLOURS)	1
*39	-	CIRCLIP	1
40	-	VALVE BODY	1
41	-	VALVE ADJUSTING KNOB	1
*42	-	VALVE PIN	1
43	PRO-408-K	AIRFLOW VALVE	1
44	GFC-2-K5	DRIP CHECK LID (KIT OF 5)	1
45	SRI-414-K2	GRAVITY CUP LID (KIT OF 2)	1
46	SRI-42-K3	FILTER (KIT OF 3)	1
47	-	GRAVITY CUP	1
48	SRI-510	GRAVITY CUP KIT	1
49	SPN-8-K2	TORX DRIVER (KIT OF 2)	1
50	SRI-50-K2	SPANNER (KIT OF 2)	1
51	SRI-51-K12	FUNNEL (KIT OF 12)	1
52	-	AIR VALVE SERVICE TOOL	1

**SERVICE PARTS**

-	PRO-415-1	SPRAY GUN REPAIR KIT (INCLUDES ITEMS MARKED *)
---	-----------	--

**CAUTION**

**IMPORTANT:** This spraygun is suitable for use with both waterbased and solvent based coating materials.

- The gun is not designed for use with highly corrosive and/or abrasive materials.
- To avoid premature degradation of parts, DeVilbiss recommends the gun is washed in neutral cleaning solution (pH 6 to 8).
- The gun is not designed to be cleaned within an ultrasonic bath.

If there is any doubt regarding the suitability of a specific material, contact your DeVilbiss Distributor or DeVilbiss direct.



**WARNING**

The spray gun must be earthed to dissipate any electrostatic charges which may be created by fluid or air flows. This can be achieved through the spray gun mounting, or conductive air/fluid hoses. Electrical bond from the spray gun to earth should be checked and a resistance of less than  $10^6$  Ohms is required.

**START-UP SEQUENCE**

- 1 Connect the gun to a clean, moisture and oil free air supply using a conductive hose.
- 2 Mix coating material to Manufacturer's instructions and strain material.
- 3 Turn fluid adjusting knob (14) clockwise to prevent fluid needle movement.
- 4 Turn spreader valve adjusting knob (19) counter clockwise to fully open.
- 5 Adjust inlet air pressure if required.
- 6 Turn fluid adjusting knob counter clockwise until first thread shows.
- 7 Test spray. If the finish is too dry, reduce airflow by reducing air inlet pressure.
- 8 If finish is too wet, reduce fluid flow by turning fluid adjusting knob (14) clockwise. If atomisation is too coarse, increase air inlet pressure. If too fine, reduce inlet pressure.
- 9 The pattern size can be reduced by turning spreader valve knob (19) clockwise.
- 10 Hold gun perpendicular to surface being sprayed. Arcing or tilting may result in uneven coating.
- 11 The recommended spray distance is 50-100mm.
- 12 Spray edges first. Overlap each stroke a minimum of 75%. Move gun at a constant speed.
- 13 Always turn off air supply and relieve pressure when gun is not in use.

**NOTE**

Depending on hose length, larger I.D. hose may be required. Install an air gauge at the gun handle. When gun is triggered on, adjust regulated pressure as required. Do not use more pressure than is necessary to atomise the material being applied. Excess pressure will create additional overspray and reduce transfer efficiency.

**NOTE**

If quick connect couplings are required, use only high flow quick connects. Other types will not flow enough air for correct gun operation.

**SPRAY GUN MAINTENANCE & CLEANING**

To clean air cap and fluid tip, brush exterior with a stiff bristle brush. If necessary to clean cap holes, use a broom straw or toothpick if possible. If a wire or hard instrument is used, extreme care must be taken to prevent scratching or burring of the holes which will cause a distorted spray pattern.

To clean fluid passages, remove excess material, then flush with gun wash solution. Wipe the gun exterior with a dampened cloth. Never completely immerse in any solvent or cleaning solutions as this is detrimental to the lubricants and life of the spray gun.

**SPRAY GUN DISASSEMBLY / ASSEMBLY**

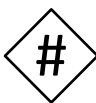
<b>KEY</b>	
	Order for disassembly - see over page <i>(reverse for assembly)</i>
<b>#</b>	<i>(reverse for assembly)</i> - see over page

## DISASSEMBLY TIP &amp; NEEDLE

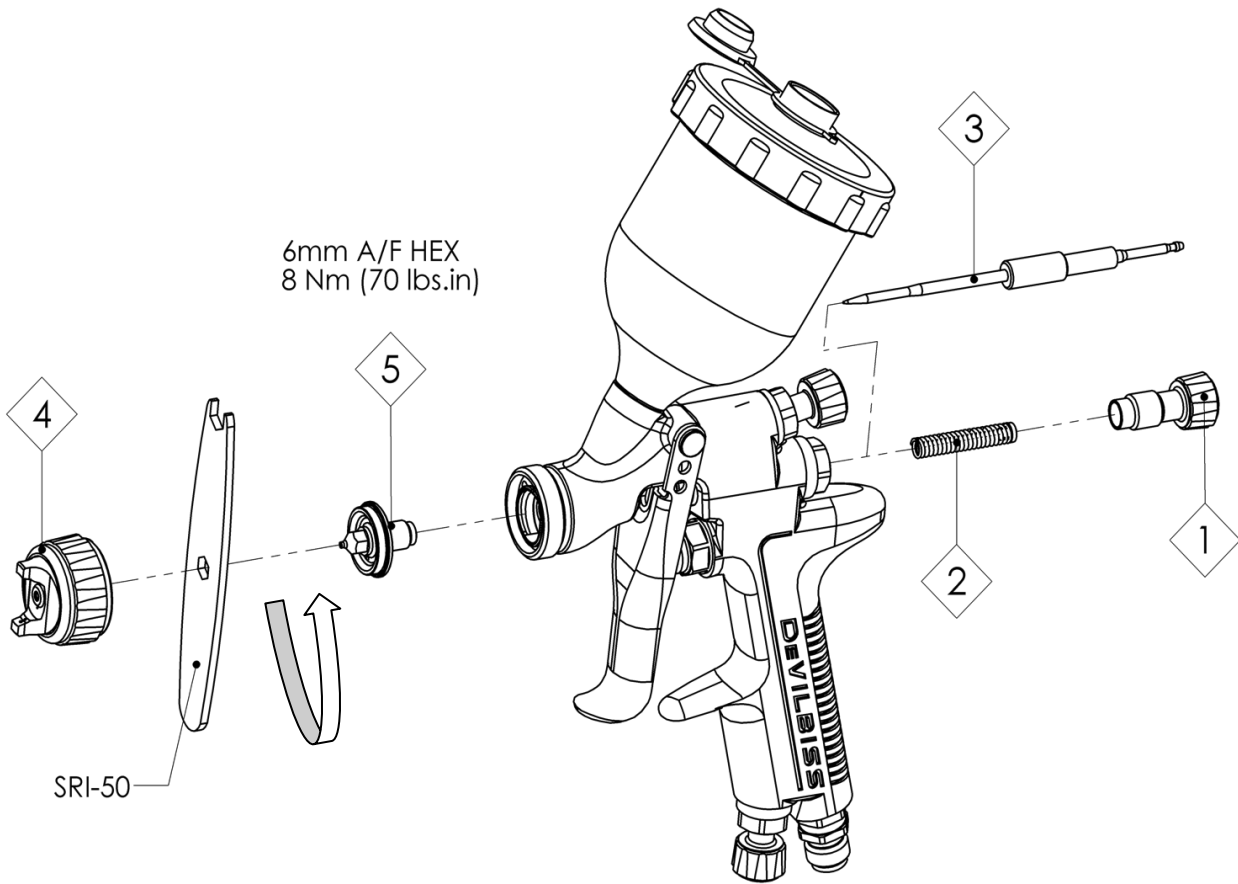
**NOTE**

When replacing the fluid tip or fluid needle, replace tip, needle and fluid packing at the same time. Using worn parts can cause fluid leakage. Do not overtighten.

**CAUTION**

To prevent damage to fluid tip or fluid needle, be sure to either:

- 1 Pull the trigger and hold while tightening or loosening the fluid tip, or,
- 2 Remove the fluid adjusting knob to relieve spring pressure against needle collar.

DISASSEMBLY AIR VALVE

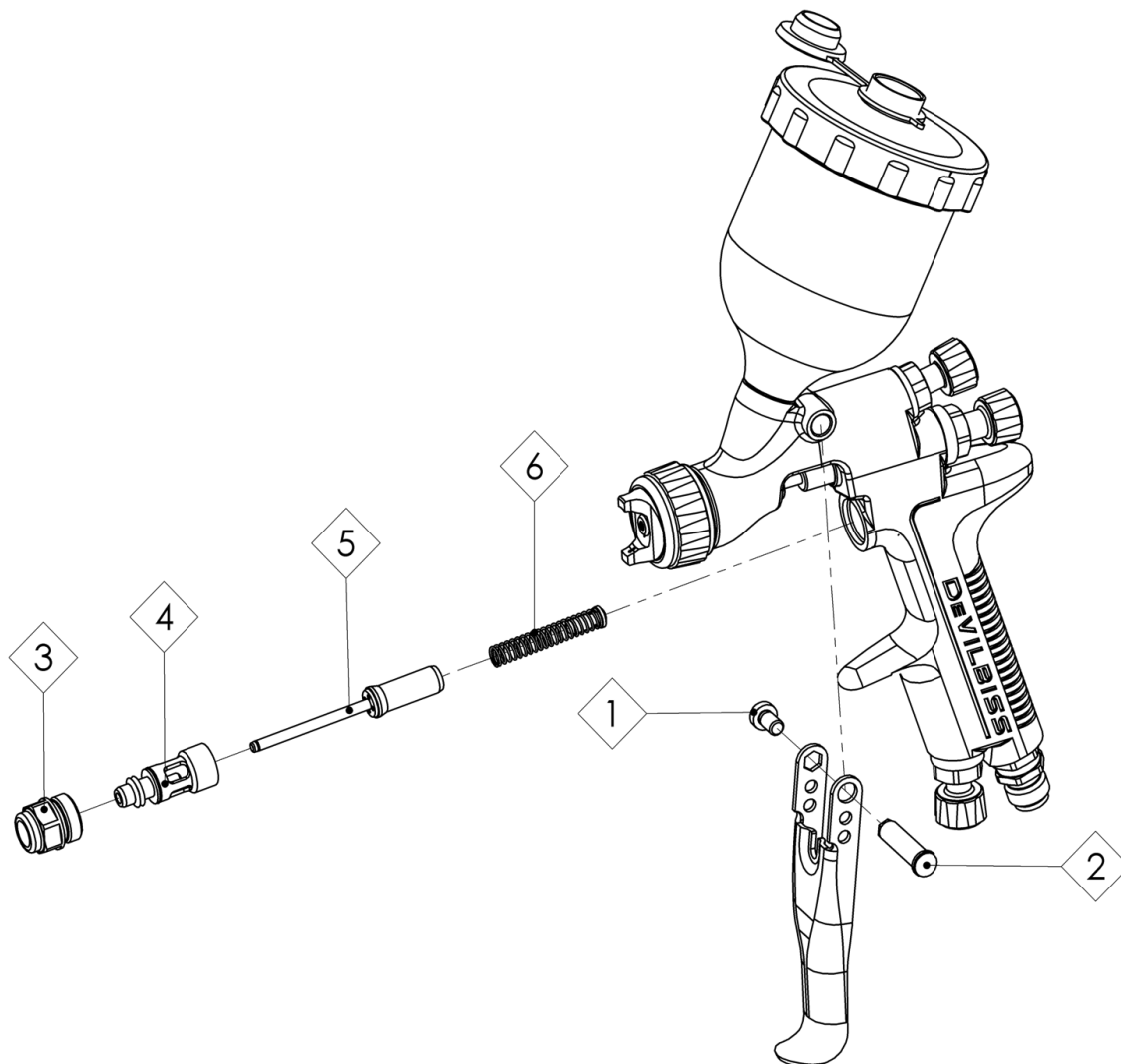

DISASSEMBLY / ASSEMBLY AIR VALVE SEALS

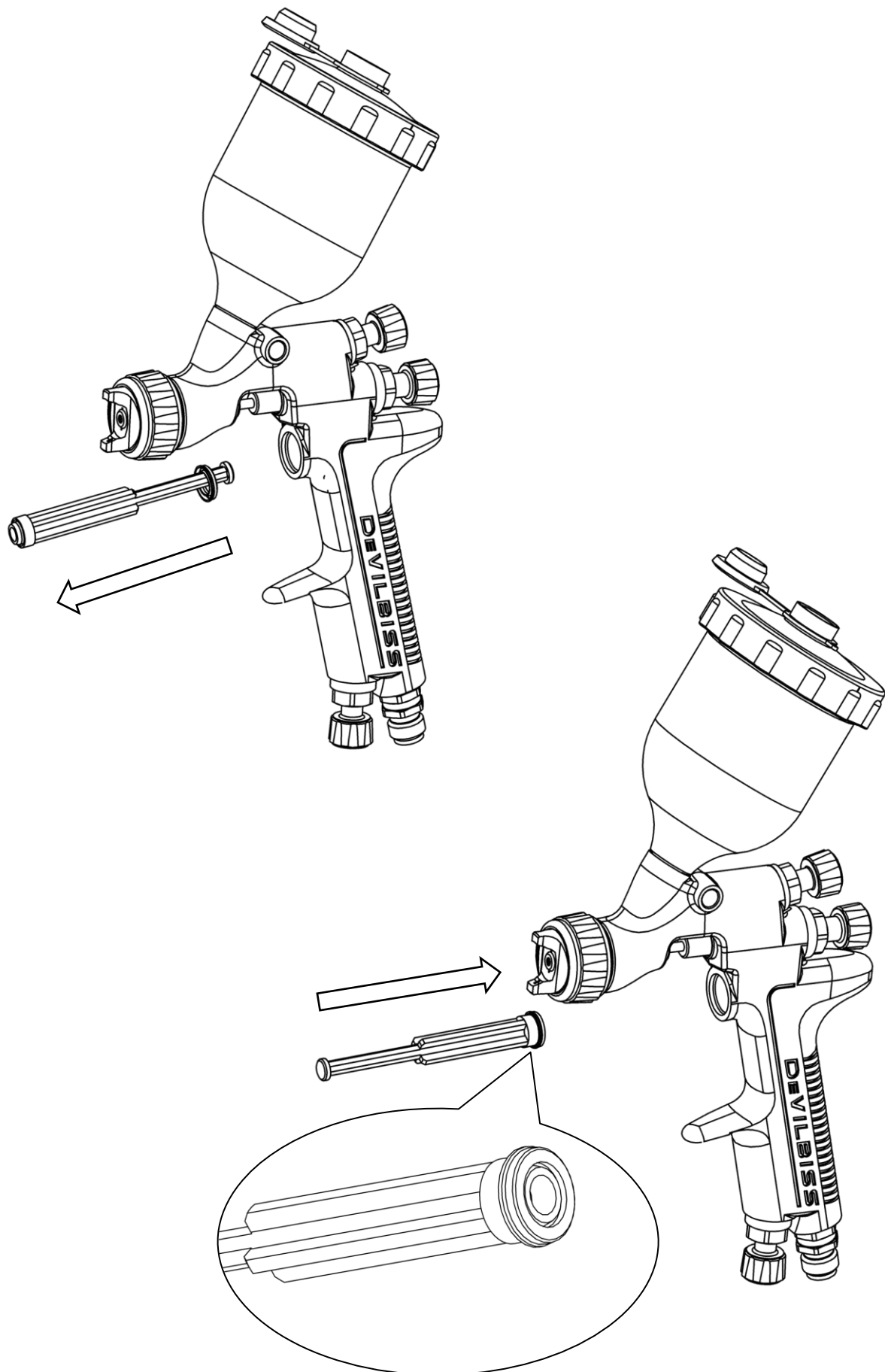

DISASSEMBLY PACKING

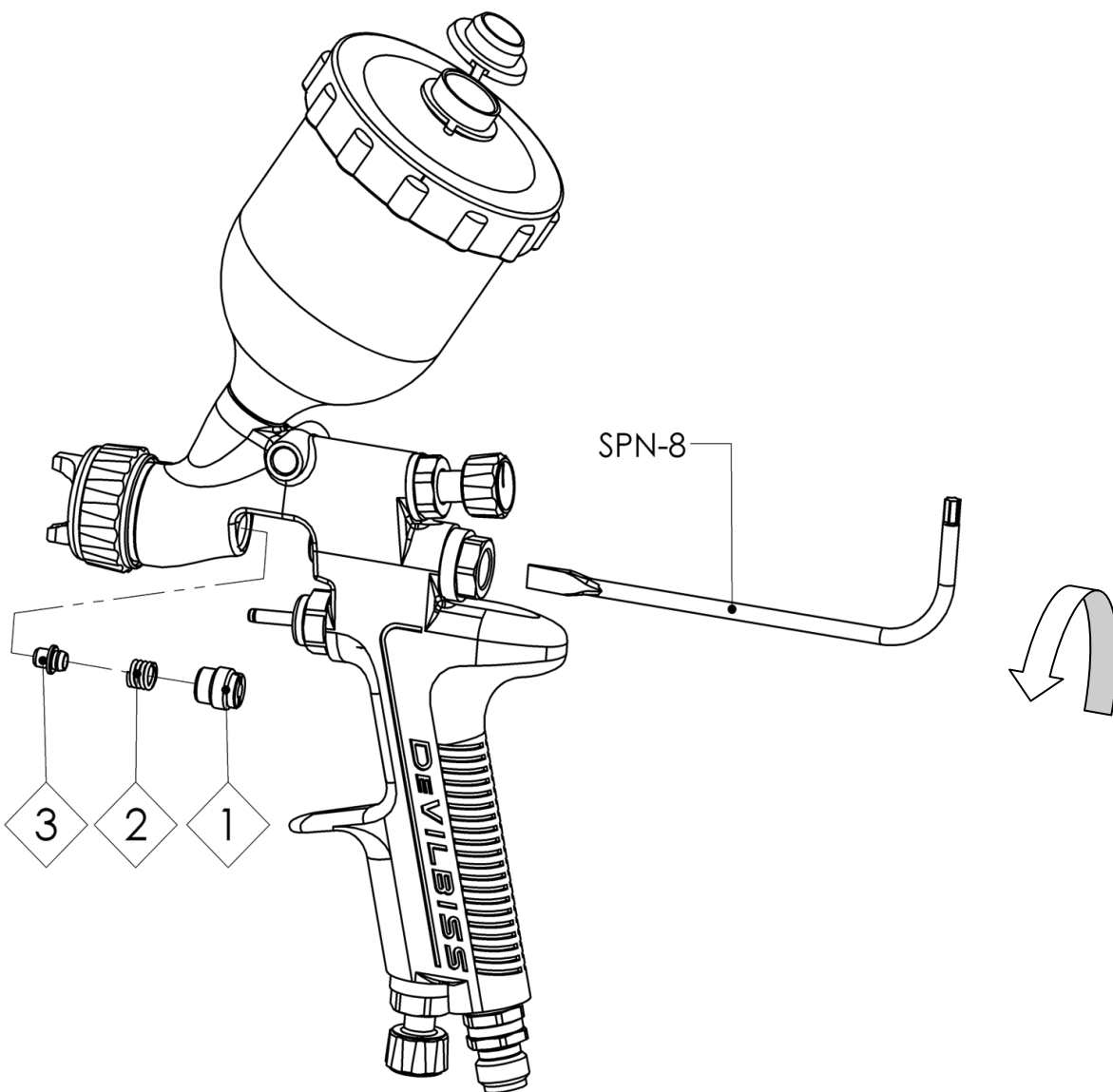

## TROUBLESHOOTING MECHANICAL PERFORMANCE

GENERAL FAULTS	CAUSE	CORRECTION
Will not spray.	No air pressure at gun.	Check air supply and air line.
	Fluid needle adjustment knob not open enough.	Open fluid needle adjustment knob.
Gun spits paint when triggering on and off.	Incorrect needle fitted to gun.	Check fluid tip/needle selection chart and fit correct item.
	Excessive needle wear.	Replace with new needle.
	Excessive fluid tip wear.	Replace with new fluid tip.
Gun spits paint when triggering on due to paint build-up inside air cap between spraying operations.	Fluid tip not fitted correctly in gun head.	Tighten.
	Fluid tip/needle leakage.	Check for damage or blockage.
Paint build-up on fluid tip.	Fluid tip not fitted correctly in gun head.	Tighten.
	Fluid tip/needle leakage.	Check for damage or blockage.
Paint build-up on air cap.	Damaged air cap holes.	Replace with new air cap.
	Gradual build-up of bounce-back on gun head.	Thoroughly clean.
Unable to get round spray	Fluid tip or sprayhead incorrectly fitted.	Remove, check components for damage and refit correctly.

When removing air cap from retaining ring, do not remove the ring seat from the retaining ring. Damage to the parts may occur. Simply wipe parts clean and reassemble with new or clean air cap.

FLUID FAULTS	CAUSE	CORRECTION
Slow fluid leak from fluid tip and needle seat.	Fluid tip internal seat scored damaged or worn.	Replace.
	Fluid needle external profile damaged or worn.	Replace.
	Contamination on needle or tip mating surfaces preventing good seal.	Thoroughly clean.
	Incorrect fluid tip for fluid needle fitted to gun.	Check tip/needle selection chart and fit correct item.
	Sluggish needle.	Lubricate packing. (GL-1)
	Tight packing nut.	Adjust.
Major fluid leak or fluid jetting from fluid tip and needle seat.	Contamination on needle or tip mating surfaces preventing good seal.	Remove tip and needle and thoroughly clean.
	Incorrect fluid tip for fluid needle fitted to gun.	Check tip/needle selection chart and fit correct item.
Slow fluid leak from needle packing.	Fluid needle packing worn or loose.	Tighten or replace as necessary.



AIR FAULTS	CAUSE	CORRECTION
Small air leak from air cap when gun is not triggered.	Air Valve Stem contaminated and not correctly seating.	Remove Air Valve Stem and thoroughly clean valve shaft and seating surfaces.
	Air Valve Stem seal damaged or missing.	Replace.

## TROUBLESHOOTING SPRAY PERFORMANCE

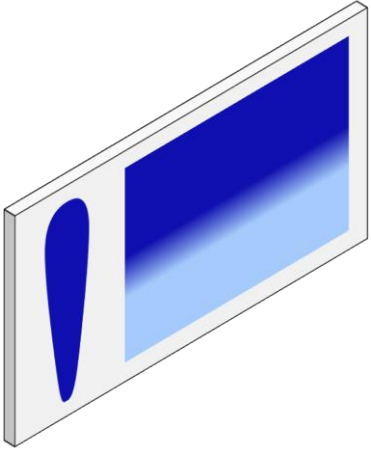
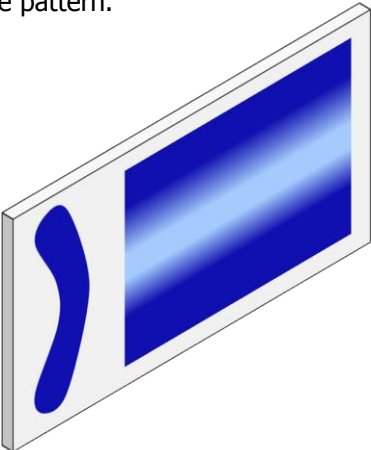
CONDITION	CAUSE	CORRECTION
Heavy top or bottom pattern. 	Material build-up on air cap, plugged horn holes, centre holes or jets.	Soak cap or tip in suitable solvent and thoroughly clean.
	Material build-up on fluid tip exterior or partially plugged fluid tip.	Replace fluid tip or air cap if necessary.
	Fluid tip or cap dirty or damaged.	Replace fluid tip or air cap if necessary.
Heavy right or left side pattern. 	Left or right side horn holes plugged.	Soak cap or tip in suitable solvent and thoroughly clean.
	Dirt or damage on left or right side of fluid tip exterior.	Replace fluid tip or air cap if necessary.
Remedies for the top-heavy, bottom-heavy, right-heavy and left-heavy patterns.		
<p>Determine if the obstruction is on the air cap or the fluid tip. Do this by making a test spray pattern. Then, rotate the cap one-half turn and spray another pattern. If the defect is inverted, obstruction is on the air cap. Clean the air cap as previously instructed. Also check for dried paint just inside the cap centre hole opening, remove by washing with solvent.</p>		
<p>If the defect is not inverted, it is on the fluid tip. Clean tip. If problem persists, renew tip.</p>		

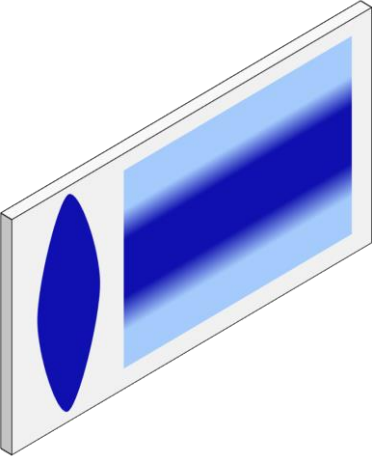
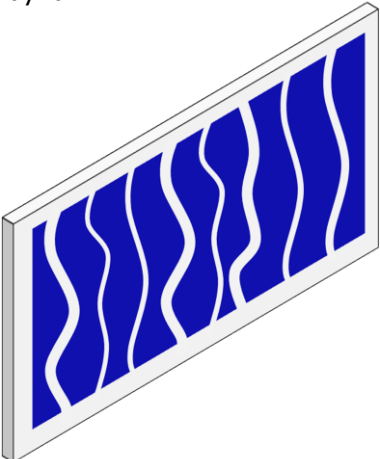
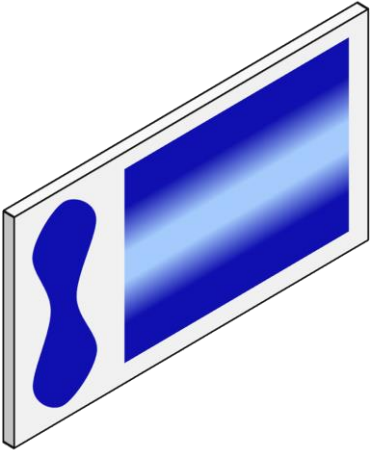
<p>Heavy centre pattern.</p> 	<p>Pattern adjustment valve set too low.</p>	<p>Turn out counter clockwise to achieve correct pattern.</p>
	<p>Too much material.</p>	<p>Reduce fluid flow by turning fluid needle adjusting screw clockwise. Reduce fluid pressure.</p>
	<p>Material too thick.</p>	<p>Thin to correct consistency.</p>
	<p>Atomising air pressure too low.</p>	<p>Increase air pressure.</p>
<p>Intermittent or 'fluttering' spray fan.</p> 	<p>Loose fluid tip.</p>	<p>Tighten.</p>
	<p>Fluid tip not seated correctly in gun head.</p>	<p>Remove fluid tip, clean components, check cone seating on tip and gun for damage or contamination.</p>
	<p>Partially obstructed fluid passage or hose.</p>	<p>Clean or replace.</p>
<p>Split spray pattern</p> 	<p>Not enough material flow.</p>	<p>Increase fluid flow by changing fluid tip size, opening needle control knob or increase fluid pressure on pressure feed container.</p>
	<p>Too high horn pressure.</p>	<p>Reduce air pressure by rotating pattern control valve clockwise.</p>
	<p>Too much air for fluid quantity used.</p>	<p>Reduce input air pressure.</p>

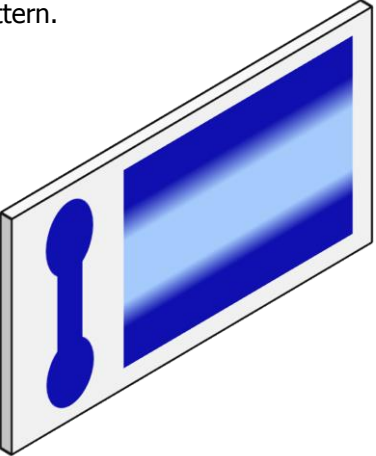
<p>Ball end heavy pattern.</p> 	<p>Too much fluid flow.</p>	<p>Change fluid tip for smaller size or change air cap for different specification air cap.</p>
<p>Excessive bounce-back.</p>	<p>Too much atomisation air pressure.</p>	<p>Reduce air pressure.</p>
	<p>Gun too far from surface.</p>	<p>Check distance (normally 150-200mm).</p>
<p>Runs and sags.</p>	<p>Too much fluid flow.</p>	<p>Adjust gun or reduce fluid pressure.</p>
	<p>Material too thin.</p>	<p>Mix properly or apply light coats/reduce fluid flow.</p>
	<p>Gun tilted at an angle.</p>	<p>Mount gun at right angle to work.</p>
<p>Thin, sandy coarse finish drying before it flows out.</p>	<p>Gun too far from surface.</p>	<p>Check distance.</p>
	<p>Too much air pressure.</p>	<p>Reduce air pressure and check spray pattern.</p>
	<p>Fluid flow too low.</p>	<p>Increase fluid flow by changing fluid tip size, supply pressure or turning needle control knob counter clockwise.</p>

## DIMENSIONS

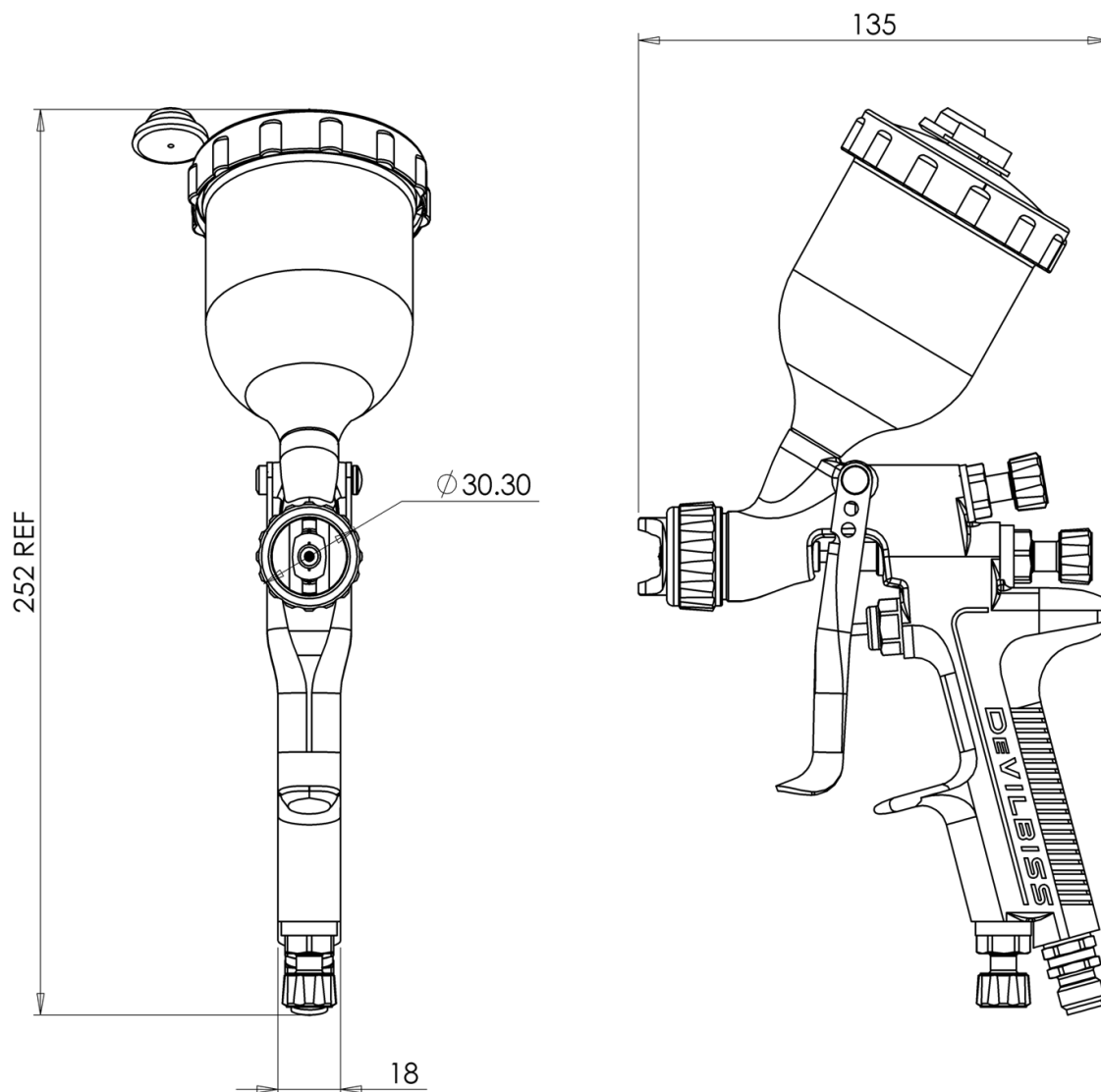

NOTES

NOTES

## WARRANTY POLICY

DeVilbiss products are covered by Finishing Brands one year materials and workmanship limited warranty. The use of any parts or accessories, from a source other than Finishing Brands, will void all warranties. For specific warranty information please contact the closest Finishing Brands location listed below.

Finishing Brands reserves the right to modify equipment specifications without prior notice. DeVilbiss®, Ransburg®, MS®, BGK®, and Binks® are registered trademarks of Carlisle Fluid Technologies, Inc., dba Finishing Brands.

© 2016 Carlisle Fluid Technologies, Inc., dba Finishing Brands.  
All rights reserved.



DeVilbiss is part of Finishing Brands, a global leader in innovative spray finishing technologies. For technical assistance or to locate an authorised distributor, contact one of our international sales and customer support locations below.

### USA/Canada

www.devilbiss.com  
info@carlisleleft.com  
Toll Free Tel: 1-800-992-4657  
Toll Free Fax: 1-888-246-5732

### Mexico

www.carlisleleft.com.mx  
ventas@carlisleleft.com.mx  
Tel: 011 52 55 5321 2300  
Fax: 011 52 55 5310 4790

### Brazil

www.devilbiss.com.br  
vendas@carlisleleft.com.br  
Tel: +55 11 5641 2776  
Fax: +55 11 5641 1256

### United Kingdom

www.carlisleleft.eu  
info@carlisleleft.eu  
Tel: +44 (0)1202 571 111  
Fax: +44 (0)1202 573 488

### France

www.carlisleleft.eu  
info@carlisleleft.eu  
Tel: +33(0)475 75 27 00  
Fax: +33(0)475 75 27 59

### Germany

www.carlisleleft.eu  
info@carlisleleft.eu  
Tel: +49 (0) 6074 403 1  
Fax: +49 (0) 6074 403 281

### China

www.carlisleleft.com.cn  
mkt@carlisleleft.com.cn  
Tel: +8621-3373 0108  
Fax: +8621-3373 0308

### Japan

www.ransburg.co.jp  
overseas-sales@carlisleleft.co.jp  
Tel: 081 45 785 6421  
Fax: 081 45 785 6517

### Australia

www.carlisleleft.com.au  
sales@carlisleleft.com.au  
Tel: +61 (0) 2 8525 7555  
Fax: +61 (0) 2 8525 7575

