

FUNCY GUN Operation Manual

SB-E-FUNCY-A

Important: Read and follow all instructions and SAFETY PRECAUTIONS before using this equipment

MODELS

FUNCY - Air Cap No. - Fluid Tip size - Type of feed (G: Gravity, S: Suction)

(例): FUNCY-343-1.3 -G ← (No.343 Air Cap - Size1.3mm - Gravity)

SPECIFICATIONS

Maximum Working Air Pressure: 9 bar , Maximum Working Fluid Pressure: 14 bar

Chart. 1

Air Cap No. Part Number	Tip size (mm)				Feed	Air consumption Gun inlet pressure	Pattern width (mm)	Application	Fluid inlet	Air inlet	Weight (g)
	1.0	1.3	1.5	1.8							
JGX-3C-343	○	○	○	○	G	225L/min 0.2MPa	250	Mid-high Volume, fine atomization, auto-refinishing, Wood, plastic & metal finishing	G1/4	G1/4	320
		○	○	○	S						

PARTS LIST

Chart. 2

Ref. No.	Part Number	Description	Qty
1	FUNCY-6	Retaining Ring Assy.	1
2	JGX-61C-K5	Seat Kit of 5	1
3	See Chart.1	Air Cap	1
4	See Chart.3	Fluid Tip	1
5	FUNCY-7	Baffle with Gasket	1
6	FUNCY-8-K5	Baffle Gasket Kit of 5	1
7	JGX-2C-G	Fluid Inlet	1
8	FUNCY-BODY-G FUNCY-BODY-S	Gun Body (not for sale)	1
9	FUNCY-44	Pattern Valve	1
10	FUNCY-443	Valve Seal Kit (3 pieces)	1
11	FUNCY-43	Air Valve	1
12	FUNCY-25-K5	Valve Spring Kit of 5	1
13	FUNCY-12	Air Valve Bushing	1
14	See Chart. 3	Needle Assy.	1
15	FUNCY-14-K5	Needle Spring Kit of 5	1
16	FUNCY-13	Adjusting Screw	1
17	JGX-463C	Needle Packing	1
18	JGX-11C-K3	Packing Gland Kit of 3	1
19	JGX-46C-K10	E-ring Kit of 10	1
20	JGX-45C	Bearing Stud	1
21	FUNCY-108	Trigger	1
22	FUNCY-42	Cheater Valve	1
23	JGX-30C	Air connector	1
24	FUN-34 (option)	Valve Seal Inserting Tool	1
25	LUNA-34	Spanner	1

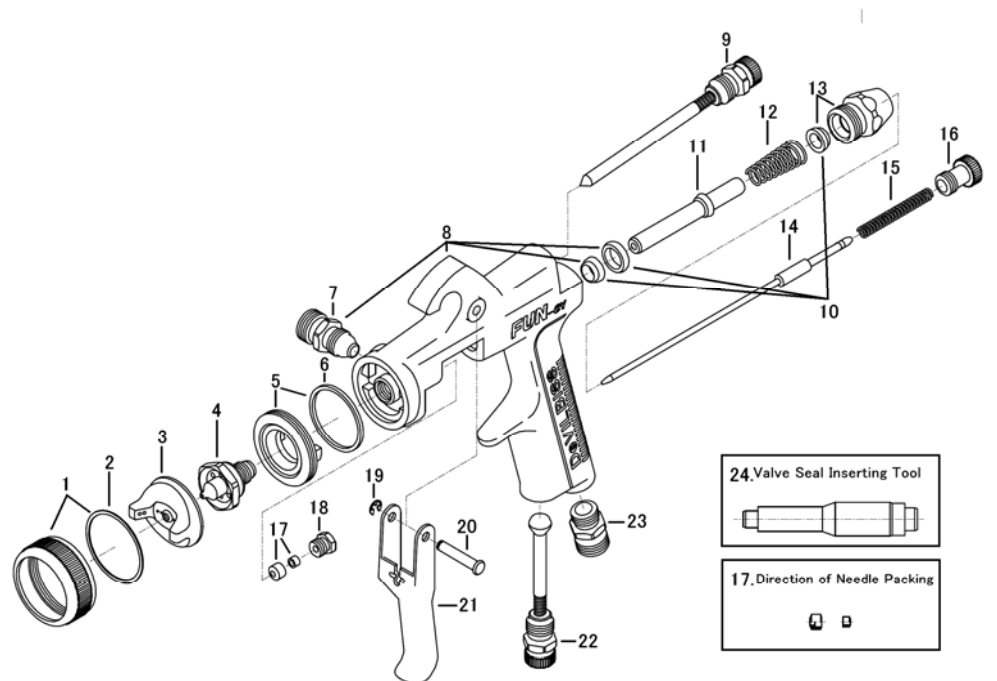

Note) Ref. No. 24 (FUN-34) is needed for Ref. 10 (FUNCY-443) installation.

When removing it, be careful not to damage the surface of seat where inserted. A damaged seat can lead air leakage.

Chart.3

Description Size (mm)	Fluid Tip	Needle
1.0	FUNCY-4-1.0	FUNCY-41-1.0
1.3	FUNCY-4-1.3	FUNCY-41-1.3
1.5	FUNCY-4-1.5	FUNCY-41-1.5
1.8	FUNCY-4-1.8	FUNCY-41-1.8

SAFETY PRECAUTIONS

This manual contains information that is important for you to know and understand. This information relates to USER SAFETY and PREVENTING EQUIPMENT PROBLEMS. Read and follow SAFETY PRECAUTIONS before using this equipment.

FIRE OR EXPLOSION HAZARD

1. When spraying, adequate exhaust must be provided to keep air free of accumulations of flammable vapors which may cause fire or explosion.
2. Smoking must never be allowed in the spray area.
3. Static electricity is generated and a static spark could be produced in the spray area. To prevent the risk of fire or explosion, ground without fail all conductive objects in the spray area.
4. Make it sure to use and ground hoses with static wire for spray gun operation. If improperly grounded, a static spark possibly produced may cause fire or explosion.
5. Fire extinguishing equipment must be provided in the spray area.
6. Solvents used for cleaning must have a flash point equal to or higher than that of the coating. Those for general cleaning must have flash points above 37.8°C(100° F) to prevent the risk of fire.

INHALING TOXIC SUBSTANCES

1. Toxic vapors and liquids are harmful to health. When spraying, adequate exhaust must be provided to keep the air free of accumulations of toxic materials and the use at all times of respiratory protective equipment must be set compulsory.
2. Always wear eye protection when spraying or cleaning the equipment.
3. Certain materials may be harmful if there is contact with the skin. Read carefully all the labels and safety performance data of the materials and solvents to be used. Appropriate clothes and gloves must be worn for spraying or cleaning the equipment.

MISUSE

1. Operators should be given adequate and appropriate training in the safe use and maintenance of this equipment.
2. Pressured liquids may injure eyes. Do not point the spray gun to any person.
3. Gravity or suction feed gun must not be used for pressure feed gun.
4. Parts with compressed air may damage the human body. Connect air hoses tightly by using a spanner so that air never leaks. If tightened loosely, hoses can be removed which may result in damaging the human body, objects to be coated and other equipment used together.
5. Parts with compressed air or under spring pressure may injure the human body. When replacing such parts, clean the spray gun by discharging the materials, discharge the air, remove air hose and fluid cup and then replace such parts by placing the gun flat. Eye protection must be worn when repairing the spray gun.
6. Do not use the gun at no more than maximum working pressure (0.69MPa).

INSTALLATION

1. The air supplied to spray gun must be cleaned air which any water, oil and solid material removed. To set up the Mist Separator and Air Transformer near the gun is recommended. The use of air not cleaned may cause coating troubles.
2. Connect fluid cup and air hoses tightly. If tightened loosely, hoses can be removed which may result in damaging the human body, objects to be coated and other equipment used together.
3. Adjust Needle Packing (17) before start using new gun. Tighten the Packing Nut (18) gradually and then to adjust the needle moving smoothly, untighten a little where the Needle (14) is not well pulled back.

OPERATION

1. The recommended pressure of air supplied to gun is different among the types (Conventional / LVMP / HVLP). However, do not supply the air pressure to gun in excess of the gun's maximum working pressure (0.69MPa).
2. Try with the pressure starting from 0.2MPa or around, as the spraying pressure varies depending upon the inner diameter of gun, triggering distance, materials etc.
3. The recommended spray distance is 200mm. If the spray distance is too far, good result does not appear.
4. In order to get uniform finishing the spray gun should be hold vertically toward the painting surface.

PREVENTIVE MAINTENANCE

1. Daily lubrication and cleaning is necessary to maintain the best condition of the gun.
2. To clean the gun body, wipe exterior with solvent dampened cloth. Do not submerge the gun body in solvent as any solids may get into the air passage and cause troubles.
3. Do not leave the gun with solvent in fluid cup. Clean the spray gun after used with clean solvent and empty the cup. To clean the fluid cup, after removing extra paint, through the appropriate solvent and flush down the residual paint.
4. The Air Cap can be immersed in solvent and brushed down for cleaning. If orifices are clogged, use a toothpick to remove obstruction. Never use a steel wire or hard instrument. This will damage air cap and result in a distorted spray pattern.
5. Do not immerse any plastic parts in solvent for long time.
6. Certain portions of gun should be lubricated. Do not lubricate to any portion where not instructed. For lubrication, SSL-10 Gun Lube* is recommended (*sold separately, vegetable not repelling materials).
7. The following portions should be lubricated regularly ; Trigger Bearing Stud (20), Pattern Valve (9), threads of cheater Valve (22) and Adjusting Screw (16), Air Valve stem (11), portion of Packing Gland (18) where Needle (14) comes in and out.
8. When installing Air Cap (3), make sure no foreign materials adhered on Retaining Ring (1) and thread of Baffle and then oil one drop of Gun Lube SSL-10.
9. Apply non-silicone grease lightly on Needle Spring (15) and Air Valve Spring (12). Do not apply too much grease as it may clog the air passage.

REPLACEMENT OF PARTS

Before replacing gun parts, remove materials from the gun for cleaning. Then release the air pressure in the gun and disconnect air hoses. All repairs should be made on a clean flat surface. Use only appropriate tools indicated for replacement of parts.

Fluid Tip (4) and Needle (14)

1. It is recommended to replace Fluid Tip (4) and Needle (14) as a set.
2. Loosen completely Pattern Valve (9) by turning the knob counterclockwise.
3. Remove Adjusting Screw (16) and Needle Spring (15) and then withdraw Needle (14) from the gun body.
4. Remove Retaining Ring (1) and Air Cap (3).
5. Remove Fluid Tip (4) by using socket wrench or offset wrench.
6. Recommended torque of Fluid tip (4) is 8N·m.

Fluid Nipple (7) and Air Connector (23)

Fluid Nipple (7) and Air Connector (23) are fixed together with fluid packing. Use offset wrench for disassembling and reassembling. When reassembling, apply fluid packing to threads of gun body.

Pattern Valve (9) and Cheater Valve (22)

When disassembling and reassembling Pattern Valve (9) and Cheater Valve (22), turn the knobs completely counterclockwise and then disassemble or reassemble them.

Valve Seal Kit (10), Air Valve (11), Valve Spring (12) and Air Valve Bushing (13)

Valve Seal Inserting Tool (24) is required for replacing Valve Seal Kit (10). When replacing Valve Seal Kit (10), be careful not to damage the surface of seals of Gun Body (8), Air Valve Bushing (13) and Air Valve (11) to prevent air leakage.

1. Remove Needle Adjust Screw (16) and Needle Spring (15) and then withdraw Needle (14) from the Gun Body (8).
2. Remove Air Valve Bushing (13) by using 17mm offset wrench.
3. Withdraw Valve Spring (12) and Air Valve (11) from the gun body.
4. Withdraw Valve Seal Kit (10), being careful not to damage where fitted to.
5. Insert each seat by using Valve Seal Inserting Tool. (24).
6. Insert Air Valve (11) to the bottom end, being careful not to damage the seat, and then insert Air Valve Spring (12).
7. Install Air Valve Bushing (13) by using offset wrench.



Needle Packing (17)

1. **Install Needle Packing (17) in the direction shown per drawing.**
2. Adjust Needle Packing (17). Tighten the Packing Gland (18) gradually and then to adjust the needle moving smoothly, untighten a little where the Needle (14) is not well pulled back.

SERVICE CHECKS

Normal spray pattern

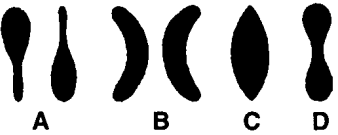

problem	Cause	Correction
Will not spray	No pressure to gun. Adjusting Screw (16) not properly adjusted.	Check air and material lines. Adjust.
Inproper spray pattern 	A,B. Material build up on the Air Cap or Fluid Tip. C,D Incorrect fluid delivery or viscosity.	A,B Clean the Air Cap or Fluid Tip. C,D Adjust.
Jerky or fluttering spray 	Insufficient material in the cup or Loose connector. Gun material passage plugged. Worn Needle Packing (17). Loose or damaged Fluid Tip (4)	Fill cup or tighten the Connector. Clean. Replace. Tighten or replace.
Fluid leaking from needle packing nut(18)	Loose Packing Gland (18). Worn or damaged Needle Packing (17).	Adjust Packing Gland(18). Replace.
Dripping from fluid tip	1. Worn or damaged Fluid Tip (4) or Needle(14). 2. Stuck Needle Packing (17) or Needle (14). 3. Tight Packing Gland (18). 4. Loose Adjusting Screw (16).	1. Replace. 2. Lubricate. 3. Adjust. 4. Tighten.

ACCESSORIES

Part No.	Description	Part No.	Description
KGP-4	Plastic Gravity Cup with Stand(400ml)	HAV-501-B	Air Adjusting Valve with Gauge
KG-250	Stainless Steel Gravity Cup with Stand(250ml)	HAF-507	Disposable Air Filter
KG-400T	Gravity Cup with Stand (400ml·Teflon coating)	SSL-10	Gun Lube (60ml)
KGL-400	Gravity Cup with Stand (Anodized Aluminum)	42884-214-K5	Cleaning Brush (kit of 5)
KGL-400-FA	KGL-400 with Free Angle Movement (400ml)	KR-555-2C	Suction Cup (1,000ml·Aluminum)
KR-470-2C	Suction Cup (700ml·Aluminum)		

BINKS·DEVILBISS DIVISION

RANSBURG INDUSTRIAL FINISHING KK

15-5 Fuku-ura 1Chome,Kanazawa-ku,Yokohama,Japan 〒236-0004

TEL 0 4 5 - 7 8 5 - 6 3 7 1 F a x 0 4 5 - 7 8 5 - 6 5 1 7