

Main Features

- **High Quality materials and surface treatments** are used in the construction to ensure both extended operational life.
- **Stainless steel fluid sections** – ideal for waterborne, solvent based and xirallic materials.
- **Equal Thrust on both pistons** - gives equal flow and pressure for both strokes.
- **Fluid Seal** - Lubricated by paint on both sides, increases life.
- **Bellows Seal** - no exposed shaft seal eliminating the need for maintenance and lubrication of shaft packing.
- **Tungsten carbide ball seats & ceramic coated pistons** – Ensure maximum operating life between servicing.
- **Low Ice Air Motor** - using quick exhaust technology (Patented design) to remove risk of valve icing. Air Motor is also lubricant free.
- **Control Valve** - Metal spool and sleeve for long life, incorporating magnetic detent to eliminate stall condition (patented design)
- **Sanitary inlet and outlet connections** guarantee a smooth internal pipe connection without paint entrapment pockets.
- **Stroke Counter Port** option to monitor life cycle data

Description

The Maple Pump is a horizontal piston pump for pumping Solvent / Waterborne Paints, Solvents and other suitable materials. The unit combines an energy efficient air motor with low shear fluid section technology from the range of Smart Electric Pumps.

The Maple Pump achieves a reciprocating drive by using high technology ground steel spool and sleeve air valves to control the air motor reversal, providing reciprocating motion.

The patented air valve design ensures a positive magnetic detent for the main and pilot air valves thus removing the possibility for a stall condition. The air motor also utilises the patented Binks Low Ice quick exhaust technology to prevent air valve freezing conditions when high cycle speeds are employed.

Equal thrust on each stroke due to the horizontal configuration incorporating the dual piston rod design gives a balanced fluid pressure output and reduces fluid pressure fluctuations to a minimum. The air pump is furnished with twin exhaust mufflers to control exhaust noise emission. An adapter kit is available to facilitate connection to a remote exhaust system if required.

Specifications

Description	Unit
Part Number	104009
Recommended max. Continuous cycle rate	-
Intermittent cycle rate	20 cycles/min (7.5LPM) 40 cycles/min (15LPM)
Fluid Volume / cycle	0.10 US Gal / 0.375 L
Equivalent Flow at 60 cycles/min	6 US Gal / 22.5 L
Air Volume per cycle	0.33 SCFM (9.3 L/m) @ 90PSI (6.2 Bar)
Ratio	3:1
Air Inlet Pressure	15 – 90 PSI / 1 – 6.2 Bar
Max. Fluid Pressure	18 Bar
Air inlet size	3/8" BSP / NPS
Inlet / Outlet Fitting	1" Sanitary
Weight	46LBS / 21 KG

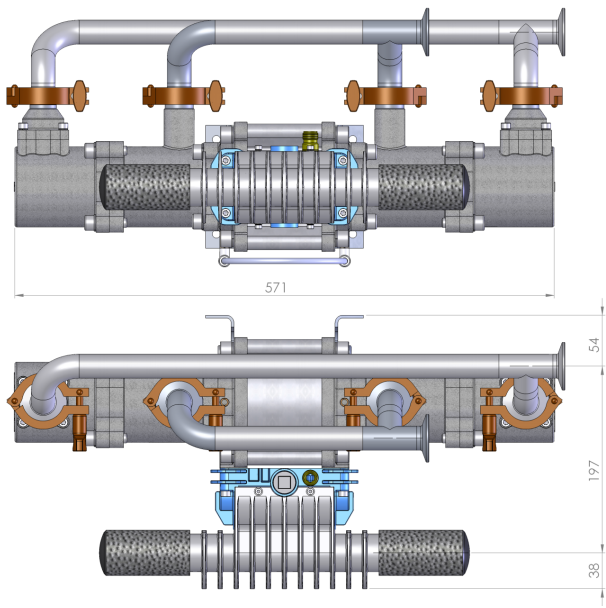

Accessories

Part. No.	Description
192006	1" Sanitary Gasket
192009	1½" Sanitary Clamp
193275	1" Sanitary - ¾" NPTF Adaptor